

JAH ALUMINIUM JACK

SERIAL NUMBERS

FROM BV0952

PRODUCT NO.

JAH1260C

SHT 1 OF
3 SHTS

REVISION

1	5498
2	6151
3	6181
4	
5	
6	
7	
8	
9	
10	
11	
12	
13	
14	
15	
16	
17	
18	
19	
20	

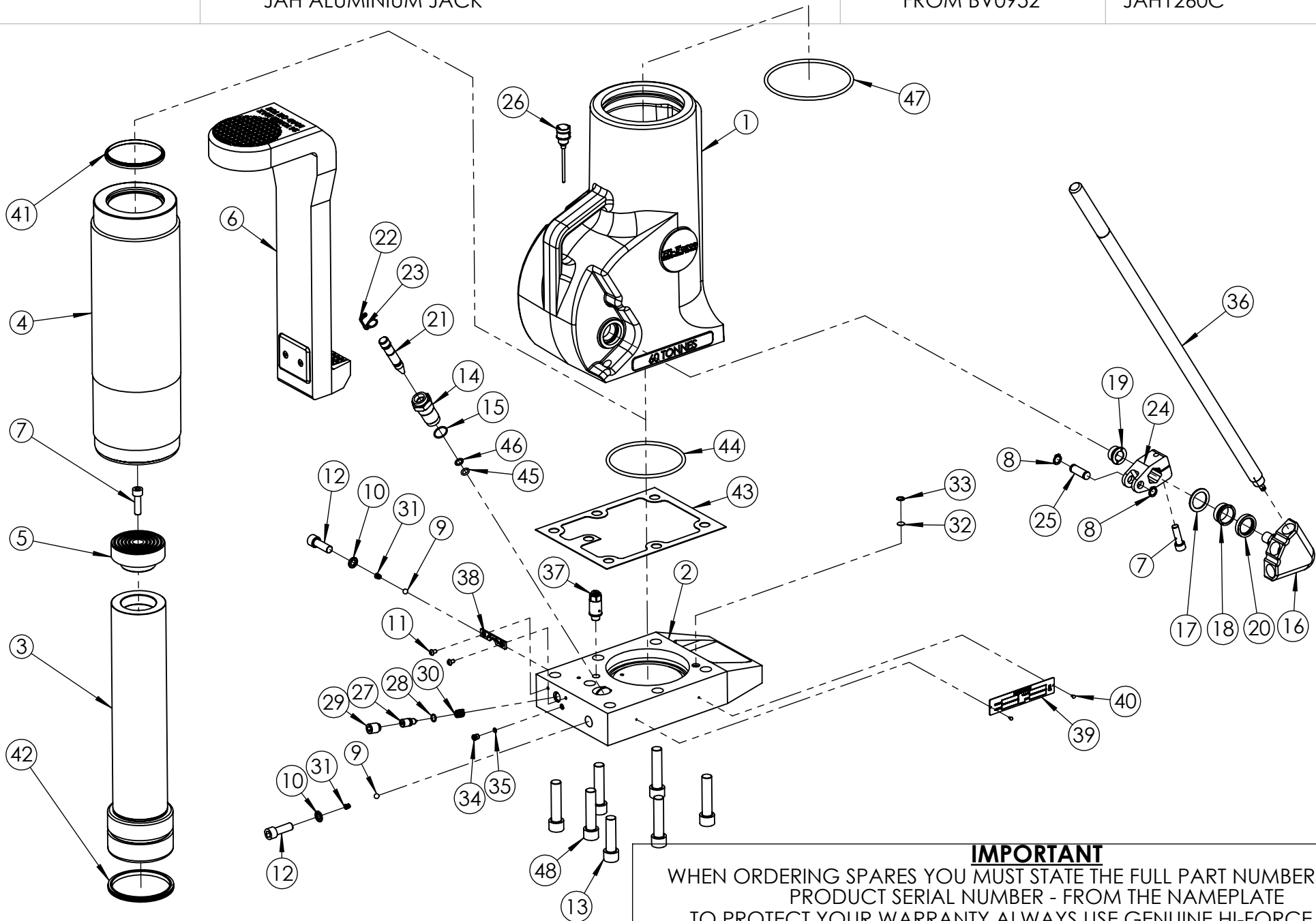

IMPORTANT
 WHEN ORDERING SPARES YOU MUST STATE THE FULL PART NUMBER AND THE
 PRODUCT SERIAL NUMBER - FROM THE NAMEPLATE
 TO PROTECT YOUR WARRANTY ALWAYS USE GENUINE HI-FORCE PARTS.

JAH ALUMINIUM JACK

SERIAL NUMBERS

FROM BV0952

PRODUCT NO.

JAH1260C

SHT 2 OF
3 SHTS

ITEM NO.	PART NUMBER	DESCRIPTION	QTY.	SPARE PARTS	SERVICE PARTS	ITEM NO.	PART NUMBER	DESCRIPTION	QTY.	SPARE PARTS	SERVICE PARTS
1	JHC108CD004	1260 CISTERN	1			29	FAS016MD020	RELEASE VALVE SCREW	1		
2	JHC108BD003	660/1260 EXTENDED BASE	1			30	SPC012CA001	SPRING	1		
3	JHC108PD006	1260 PLAIN RAM	1			31	SPC009PA001	CONICAL SPRING	2		
4	JHC108LD006	1260 LINER	1			32	FFC012MA001	SUCTION FILTER	1		
5	JHC108AD005	60T CLAW RAM CAP	1			33	STC013BA000	RETAINING CLIP	1		
6	JHA108DD004	JAH 12IN 60T CLAW	1			34	FPC008PM003	PLUG	1		
7	BLC010LD035	M10 x 35 SOCKET CAP HEAD SCREW	2			35	SEC008RA002	O-RING - I.D. 5.0 mm C.S. 1.5 mm, NITRILE 70	1		
8	STC011AA001	TUMBLER CIRCLIP N1400/0050	2			36	HLA022BK001	JAH HANDLE ASSEMBLY	1		
9	BAC008SN000	Ø8 mm STEEL BALL GRADE 100	2			37	VRA001AF002	RELIEF VALVE	1		
10	WAC012KD000	DOWTY WASHER	2	x	✓	38	JHC000GZ001	RELEASE PLATE	1		
11	BLC005HH008	M5 x 8 BUTTON HEAD SCREW	2			39	LAC000JC001	NAMEPLATE 131 x 30 mm	1	x	
12	BLC012MD035	M12 x 35 SOCKET CAP HD SCREW	2			40	FAS002HZ001	NO.4 x 3/16 HAMMER DRIVE SCREW	2		
13	BLC016NC060	SOCKET CAP HD SCREW	1			41	SEC090XE001	A1 WIPER	1	x	✓
14	JHC000KZ002	PUMP BARREL	1			42	SEC108GA001	PISTON SEAL	1	x	✓
15	SEC024RF001	O-RING - I.D. 20.35mm, C.S. 1.78mm, NITRILE 70	1	x	✓	43	JHC108YD001	60T BASE GASKET	1	x	✓
16	JHC000QZ002	QUADRANT SHAFT	1			44	SEC130RF001	O-RING	1	x	✓
17	JHC000QS001	SPACER	1			45	SEC014RA001	O-RING - I.D. 9.19mm, C.S. 2.62mm, NITRILE 90	1	x	✓
18	BSC028LC002	QUADRANT SHAFT OUTER BEARING	1			46	SEC014BA001	BACK UP RING	1	x	✓
19	BSC017LC001	QUADRANT SHAFT INNER BEARING	1			47	SEC146RA001	O-RING	1	x	✓
20	SEC028ME001	ROTARY SHAFT SEAL	1			48	BLC016NC070	SOCKET CAP HD SCREW	6		
21	JHC000UZ001	PUMP PLUNGER	1								
22	JHC000UZ002	PUMP PLUNGER CIRCLIP	1								
23	JHC000UZ003	PUMP PLUNGER CIRCLIP FASTENER	1								
24	JHC000JZ001	JACK TUMBLER	1								
25	JHC000TZ001	TUMBLER ROLLER	1								
26	JHA000DA002	DIPSTICK ASSEMBLY	1								
27	JAC010JC002	RELEASE VALVE SPINDLE	1								
28	SEC013RA001	O-RING - I.D. 9.25mm, C.S. 1.78mm, NITRILE 90	1	x	✓						

REVISION

1 5498

2 6151

3 6181

4

5

6

7

8

9

10

11

12

13

14

15

16

17

18

19

20

NOTE:

- ALL PARTS AVAILABLE TO ORDERED AS AN INDIVIDUAL SPARE PARTS (UNLESS MARKED WITH x).
- PARTS MARKED WITH ✓ ARE ONLY AVAILABLE IN **JAH60TP3-K SERVICE KIT**. (REFER TO JAH60TP3-K : SERVICE KIT EVD FOR FULL PARTS LIST).
- ITEM NO. 18 - **BSC028LC002**, REQUIRES TOOL **ATC035BJ001** (TO BE ORDERED SEPARATELY).
- ITEM NO. 19 - **BSC017LC001**, REQUIRES TOOL **ATC027PT002** (TO BE ORDERED SEPARATELY).

IMPORTANT

WHEN ORDERING SPARES YOU MUST STATE THE FULL PART NUMBER AND THE PRODUCT SERIAL NUMBER - FROM THE NAMEPLATE TO PROTECT YOUR WARRANTY ALWAYS USE GENUINE HI-FORCE PARTS.

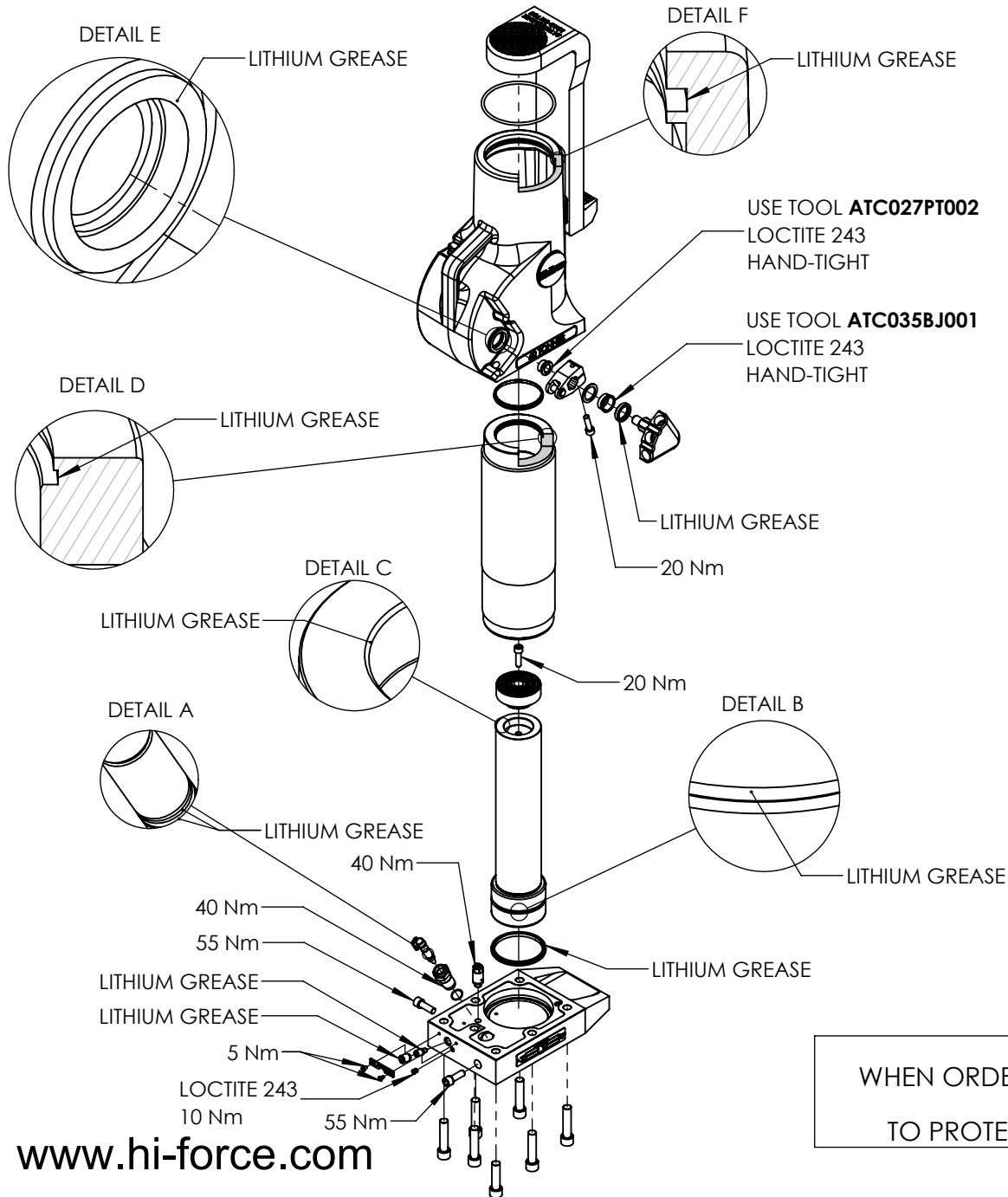

BASE BOLT TIGHTENING SEQUENCE

ALL BASE BOLTS TIGHTENED EVENLY BY HAND USING AN ALLEN KEY, FOLLOWED BY TIGHTENING SEQUENCE AS BELOW (E.G. BOLTS TORQUED IN ORDER: 1.1, 2.1, 3.1,..... TO 30Nm. FOLLOWED BY SECONDARY TIGHTENING SEQUENCE: 1.2, 2.2, 3.2,..... TO 80 Nm. FINAL TIGHTENING SEQUENCE: 1.3, 2.3, 3.3, TO 140 Nm.

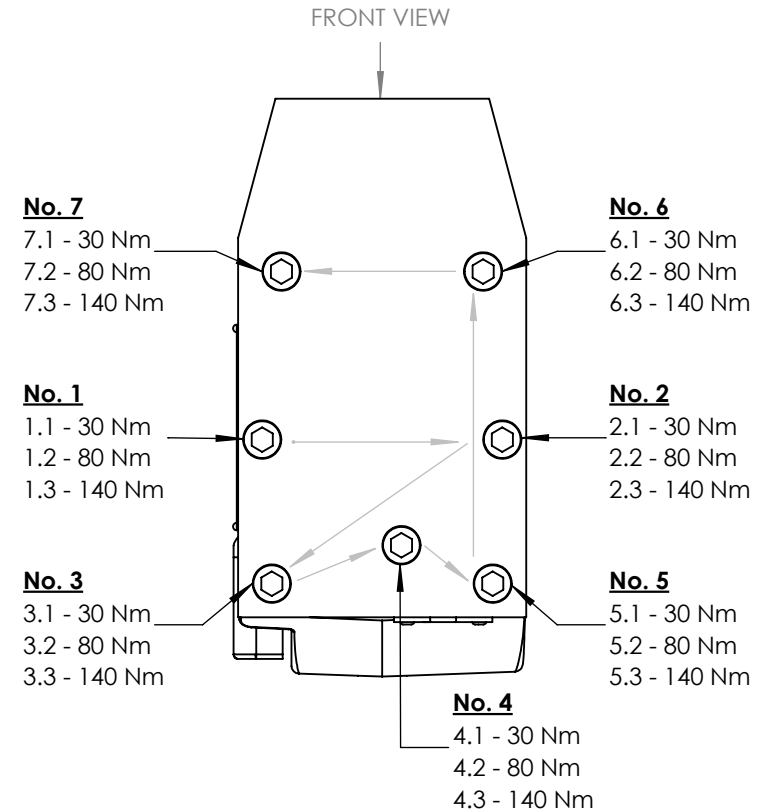

NOTE: ONCE ALL BOLTS HAVE BEEN FULLY TORQUED. ALL BOLTS TO BE RETORQUED AT 100% TORQUE VALUE, CLOCKWISE STARTING AT BOLT No. 7

IMPORTANT

WHEN ORDERING SPARES YOU MUST STATE THE FULL PART NUMBER AND THE PRODUCT SERIAL NUMBER - FROM THE NAMEPLATE TO PROTECT YOUR WARRANTY ALWAYS USE GENUINE HI-FORCE PARTS.

REVISION

1	5498
2	6151
3	6181
4	
5	
6	
7	
8	
9	
10	
11	
12	
13	
14	
15	
16	
17	
18	
19	
20	

REVISION

1	6159
2	
3	
4	
5	
6	
7	
8	
9	
10	
11	
12	
13	
14	
15	
16	
17	
18	
19	
20	

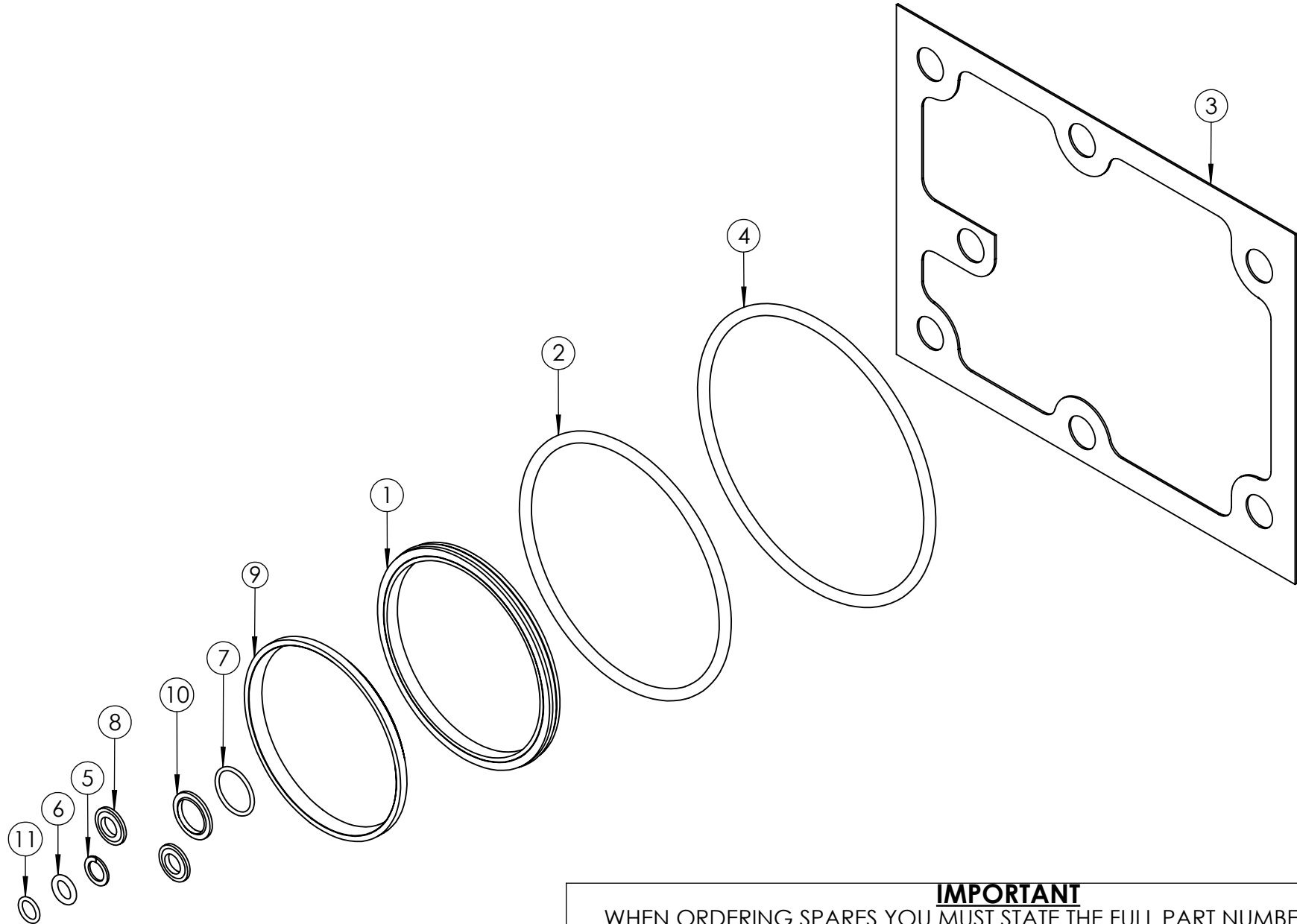

IMPORTANT

WHEN ORDERING SPARES YOU MUST STATE THE FULL PART NUMBER AND THE PRODUCT SERIAL NUMBER - FROM THE LABEL TO PROTECT YOUR WARRANTY ALWAYS USE GENUINE HI-FORCE PARTS.

ITEM NO.	PART NUMBER	DESCRIPTION	QTY.
1	SEC108GA001	PISTON SEAL	1
2	SEC130RF001	O-RING	1
3	JHC108YD001	60T BASE GASKET	1
4	SEC146RA001	O-RING	1
5	SEC014BA001	BACK UP RING	1
6	SEC014RA001	O-RING - I.D. 9.19mm, C.S. 2.62mm, NITRILE 90	1
7	SEC024RF001	O-RING - I.D. 20.35mm, C.S. 1.78mm, NITRILE 70	1
8	WAC012KD000	DOWTY WASHER	2
9	SEC090XE001	A1 WIPER	1
10	WAC016KD001	DOWTY WASHER	1
11	SEC013RA001	O-RING - I.D. 9.25mm, C.S. 1.78mm, NITRILE 90	1

REVISION

1 6159

2

3

4

5

6

7

8

9

10

11

12

13

14

15

16

17

18

19

20

IMPORTANT

WHEN ORDERING SPARES YOU MUST STATE THE FULL PART NUMBER AND THE PRODUCT SERIAL NUMBER - FROM THE LABEL TO PROTECT YOUR WARRANTY ALWAYS USE GENUINE HI-FORCE PARTS.