

REVISION

1	5498
2	6151
3	6181
4	
5	
6	
7	
8	
9	
10	
11	
12	
13	
14	
15	
16	
17	
18	
19	
20	

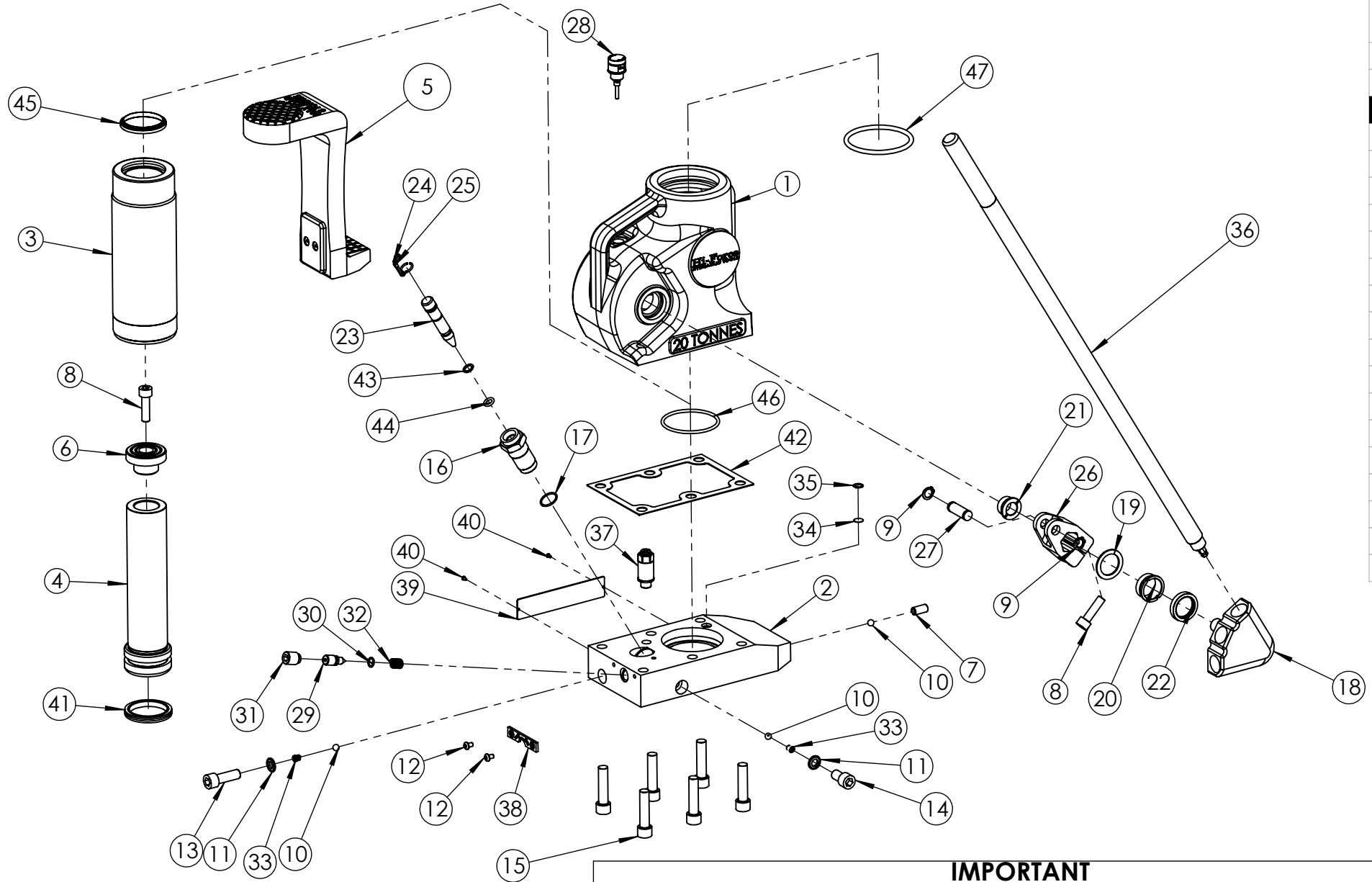

IMPORTANT
WHEN ORDERING SPARES YOU MUST STATE THE FULL PART NUMBER AND THE
PRODUCT SERIAL NUMBER - FROM THE NAMEPLATE
TO PROTECT YOUR WARRANTY ALWAYS USE GENUINE HI-FORCE PARTS.

ITEM NO.	PART NUMBER	DESCRIPTION	QTY.	SPARE PARTS	SERVICE PARTS	ITEM NO.	PART NUMBER	DESCRIPTION	QTY.	SPARE PARTS	SERVICE PARTS
1	JHC060CB003	620 CISTERN	1			33	SPC009PA001	CONICAL SPRING	2		
2	JHC060BB003	620/1220 EXTENDED BASE	1			34	FFC012MA001	SUCTION FILTER	1		
3	JHC060LB005	620 LINER	1			35	STC013BA000	RETAINING CLIP	1		
4	JHC060PB005	620 PLAIN RAM	1			36	HLA022BK001	JAH HANDLE ASSEMBLY	1		
5	JHA060DB003	JAH 6" 20T CLAW	1			37	VRA001AF002	RELIEF VALVE	1		
6	JHC060AB002	RAM CAP	1			38	JHC000GZ001	RELEASE PLATE	1		
7	FAS010MA020	M10 x 20 CUP POINT SCREW	1			39	LAC000JC001	NAMEPLATE 131 x 30 mm	1	✘	
8	BLC010LD035	M10 x 35 SOCKET CAP HEAD SCREW	2			40	FAS002HZ001	NO.4 x 3/16 HAMMER DRIVE SCREW	2		
9	STC011AA001	TUMBLER CIRCLIP N1400/0050	2			41	SEC060GA001	PISTON SEAL	1	✘	✓
10	BAC008SN000	Ø8 mm STEEL BALL GRADE 100	3			42	JHC060YB001	20T BASE GASKET	1	✘	✓
11	WAC012KD000	DOWTY WASHER	2	✘	✓	43	SEC014BA001	BACK UP RING	1	✘	✓
12	BLC005HH008	M5 x 8 BUTTON HEAD SCREW	2			44	SEC014RA001	O-RING - I.D. 9.19mm, C.S. 2.62mm, NITRILE 90	1	✘	✓
13	BLC012MD035	M12 x 35 SOCKET CAP HD SCREW	1			45	SEC051XE003	WIPER	1	✘	✓
14	BLC012MD020	M12 x 20 SOCKET CAP HD SCREW	1			46	SEC075RA003	ORING - I.D. 68.26mm, C.S. 3.53mm, NITRILE 90	1	✘	✓
15	BLC012MC050	M12 X 50mm, HEX SOCKET CAP HEAD SCREW	6			47	SEC089RA002	O-RING - I.D. 78.74 mm, C.S. 5.34 mm, NITRILE 90	1	✘	✓
16	JHC000KZ002	PUMP BARREL	1								
17	SEC024RF001	O-RING - I.D. 20.35mm, C.S. 1.78mm, NITRILE 70	1	✘	✓						
18	JHC000QZ002	QUADRANT SHAFT	1								
19	JHC000QS001	SPACER	1								
20	BSC028LC002	QUADRANT SHAFT OUTER BEARING	1								
21	BSC017LC001	QUADRANT SHAFT INNER BEARING	1								
22	SEC028ME001	ROTARY SHAFT SEAL	1								
23	JHC000UZ001	PUMP PLUNGER	1								
24	JHC000UZ002	PUMP PLUNGER CIRCLIP	1								
25	JHC000UZ003	PUMP PLUNGER CIRCLIP FASTENER	1								
26	JHC000JZ001	JACK TUMBLER	1								
27	JHC000TZ001	TUMBLER ROLLER	1								
28	JHA000DA003	DIPSTICK ASSEMBLY	1								
29	JAC010JC002	RELEASE VALVE SPINDLE	1								
30	SEC013RA001	O-RING - I.D. 9.25mm, C.S. 1.78mm, NITRILE 90	1	✘	✓						
31	FAS016MD020	RELEASE VALVE SCREW	1								
32	SPC012CA001	SPRING	1								

NOTE:

- ALL PARTS AVAILABLE TO ORDERED AS AN INDIVIDUAL SPARE PARTS (UNLESS MARKED WITH ✘)

- PARTS MARKED WITH ✓ ARE ONLY AVAILABLE IN **JAH20TP3-K SERVICE KIT**. (REFER TO JAH20TP3-K : SERVICE KIT EVD FOR FULL PARTS LIST).

- ITEM NO. 20 - **BSC028LC002**, REQUIRES TOOL **ATC035BJ001** (TO BE ORDERED SEPARATELY).

- ITEM NO. 21 - **BSC017LC001**, REQUIRES TOOL **ATC027PT002** (TO BE ORDERED SEPARATELY).

IMPORTANT

WHEN ORDERING SPARES YOU MUST STATE THE FULL PART NUMBER AND THE PRODUCT SERIAL NUMBER - FROM THE NAMEPLATE TO PROTECT YOUR WARRANTY ALWAYS USE GENUINE HI-FORCE PARTS.

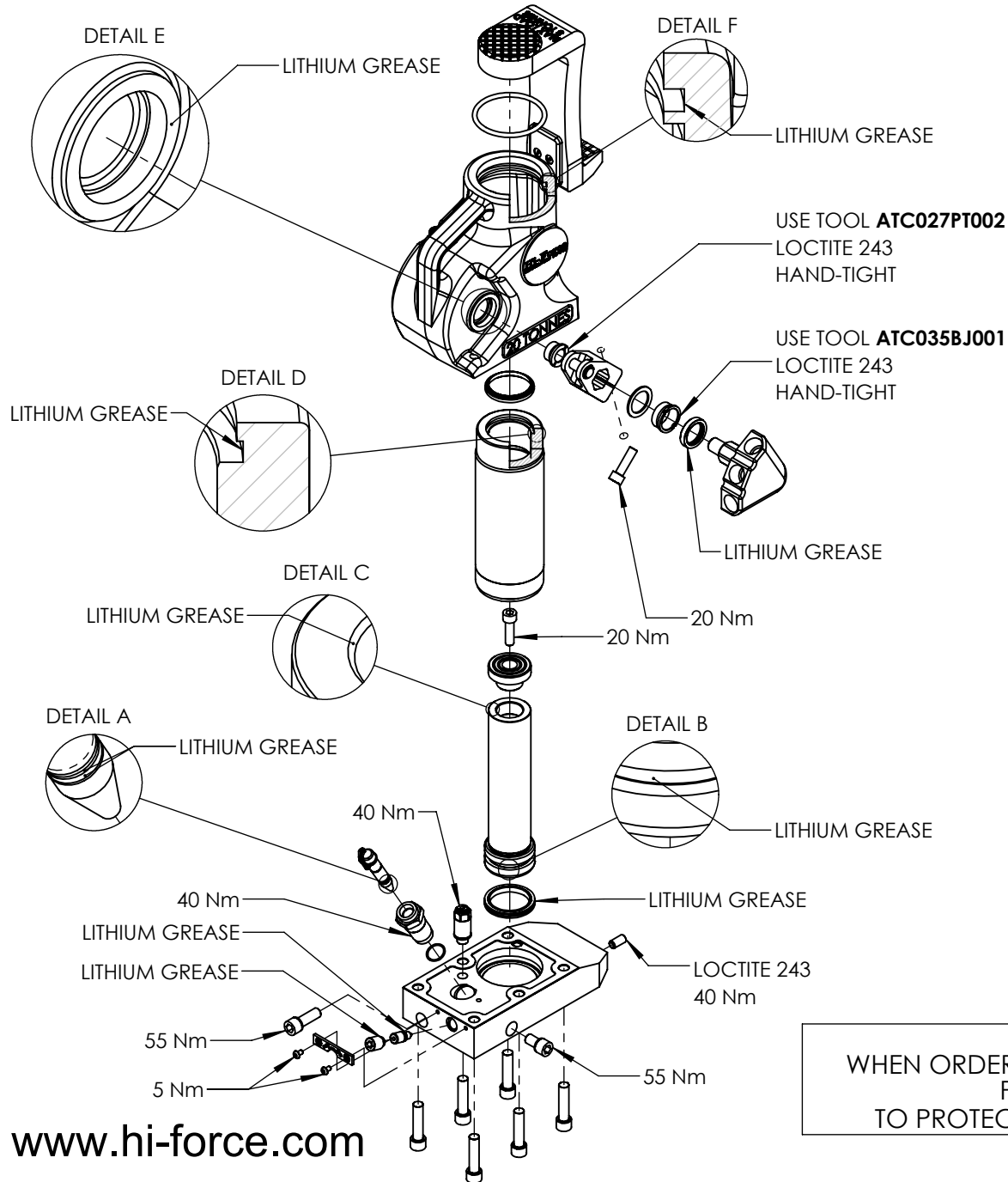

BASE BOLT TIGHTENING SEQUENCE

ALL BASE BOLTS TIGHTENED BY HAND USING AN ALLEN KEY, FOLLOWED BY TIGHTENING SEQUENCE AS BELOW (E.G. BOLTS TORQUED IN ORDER: 1.1, 2.1, 3.1, TO 20Nm. FOLLOWED BY SECONDARY TIGHTENING SEQUENCE 1.2, 2.2, 3.2, TO 60 Nm. FINAL TIGHTENING SEQUENCE 1.3, 2.3, 3.3, TO 100 Nm)

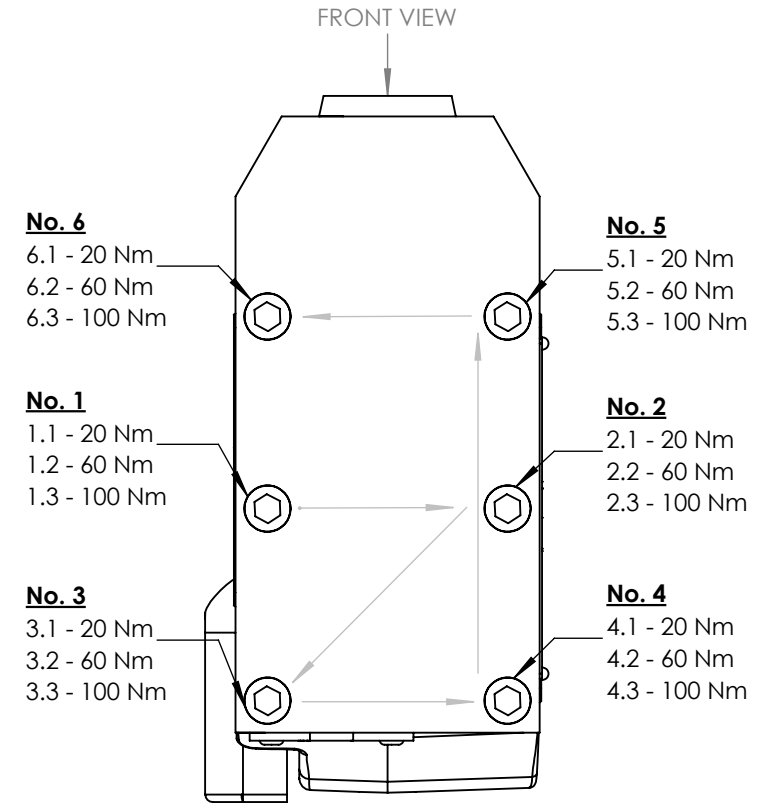

NOTE: ONCE ALL BOLTS HAVE BEEN FULLY TORQUED, ALL BOLTS TO BE RETORQUED AT 100% TORQUE VALUE, CLOCKWISE STARTING AT BOLT No. 6

IMPORTANT

WHEN ORDERING SPARES YOU MUST STATE THE FULL PART NUMBER AND THE PRODUCT SERIAL NUMBER - FROM THE NAMEPLATE TO PROTECT YOUR WARRANTY ALWAYS USE GENUINE HI-FORCE PARTS.

REVISION

1	5498
2	6151
3	6181
4	
5	
6	
7	
8	
9	
10	
11	
12	
13	
14	
15	
16	
17	
18	
19	
20	

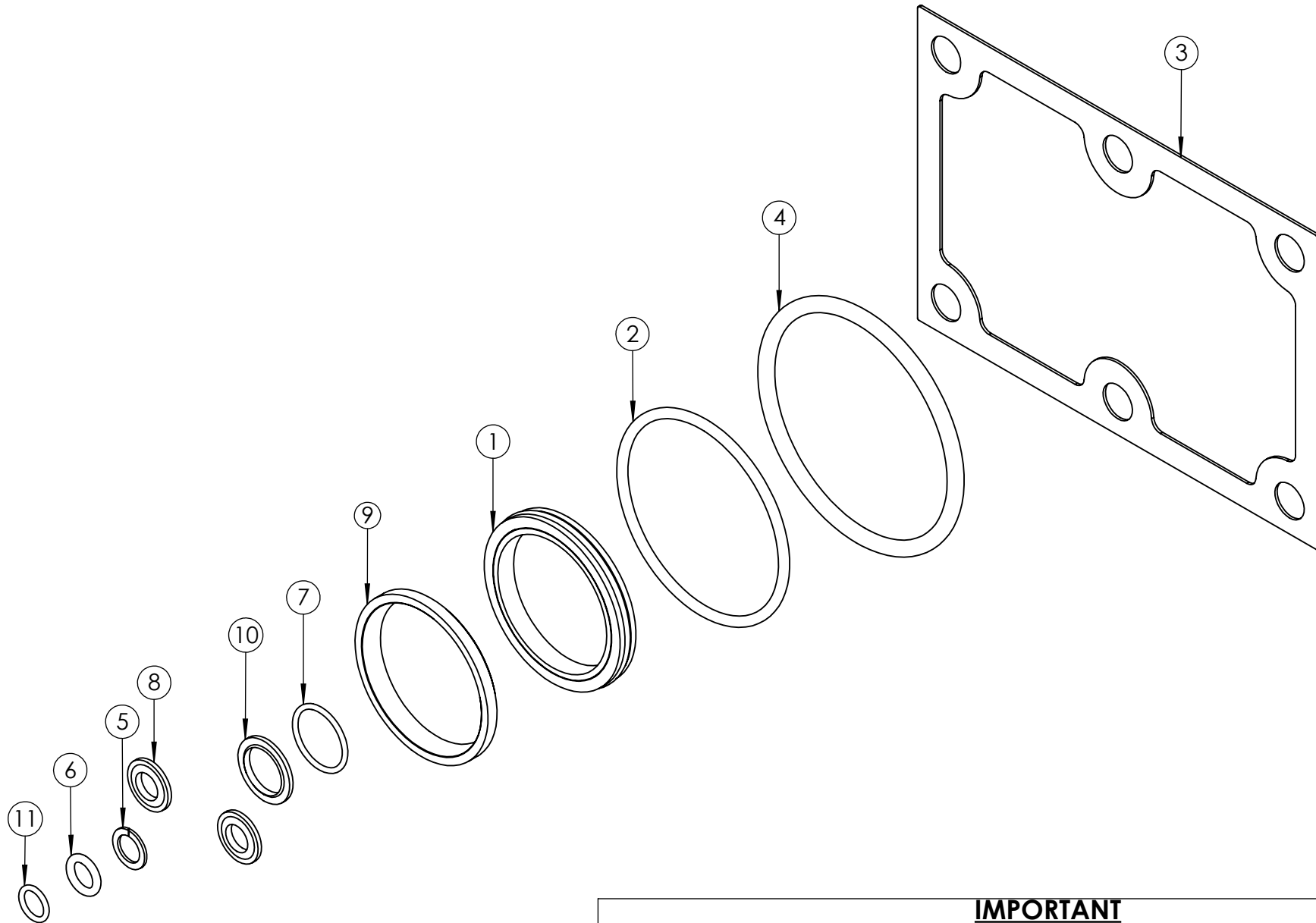

REVISION

1	6159
2	
3	
4	
5	
6	
7	
8	
9	
10	
11	
12	
13	
14	
15	
16	
17	
18	
19	
20	

IMPORTANT

WHEN ORDERING SPARES YOU MUST STATE THE FULL PART NUMBER AND THE PRODUCT SERIAL NUMBER - FROM THE LABEL TO PROTECT YOUR WARRANTY ALWAYS USE GENUINE HI-FORCE PARTS.

ITEM NO.	PART NUMBER	DESCRIPTION	QTY.
1	SEC060GA001	PISTON SEAL	1
2	SEC075RA003	ORING	1
3	JHC060YB001	20T BASE GASKET	1
4	SEC089RA002	O-RING - I.D. 78.74 mm, C.S. 5.34 mm, NITRILE 70	1
5	SEC014BA001	BACK UP RING	1
6	SEC014RA001	O-RING - I.D. 9.19mm, C.S. 2.62mm, NITRILE 90	1
7	SEC024RF001	O-RING - I.D. 20.35mm, C.S. 1.78mm, NITRILE 70	1
8	WAC012KD000	DOWTY WASHER	2
9	SEC051XE003	WIPER	1
10	WAC016KD001	DOWTY WASHER	1
11	SEC013RA001	O-RING - I.D. 9.25mm, C.S. 1.78mm, NITRILE 90	1

REVISION

1 6159

2

3

4

5

6

7

8

9

10

11

12

13

14

15

16

17

18

19

20

IMPORTANT

WHEN ORDERING SPARES YOU MUST STATE THE FULL PART NUMBER AND THE PRODUCT SERIAL NUMBER - FROM THE LABEL TO PROTECT YOUR WARRANTY ALWAYS USE GENUINE HI-FORCE PARTS.