

This 'original instructions' document assumes that the operator carrying out any operation with this product is trained and competent to do so. This manual does not attempt to cover all details or variations in the equipment. Nor does this manual claim to provide for every possible contingency met in connection with the installation, operation, or maintenance thereof. Should further information be desired, or should a particular problem arise which is not covered in sufficient detail, the matter should be referred to Hi-Force.

OPERATING INSTRUCTION MANUAL

HEP1 SERIES | ELECTRIC DRIVEN MINI PUMPS

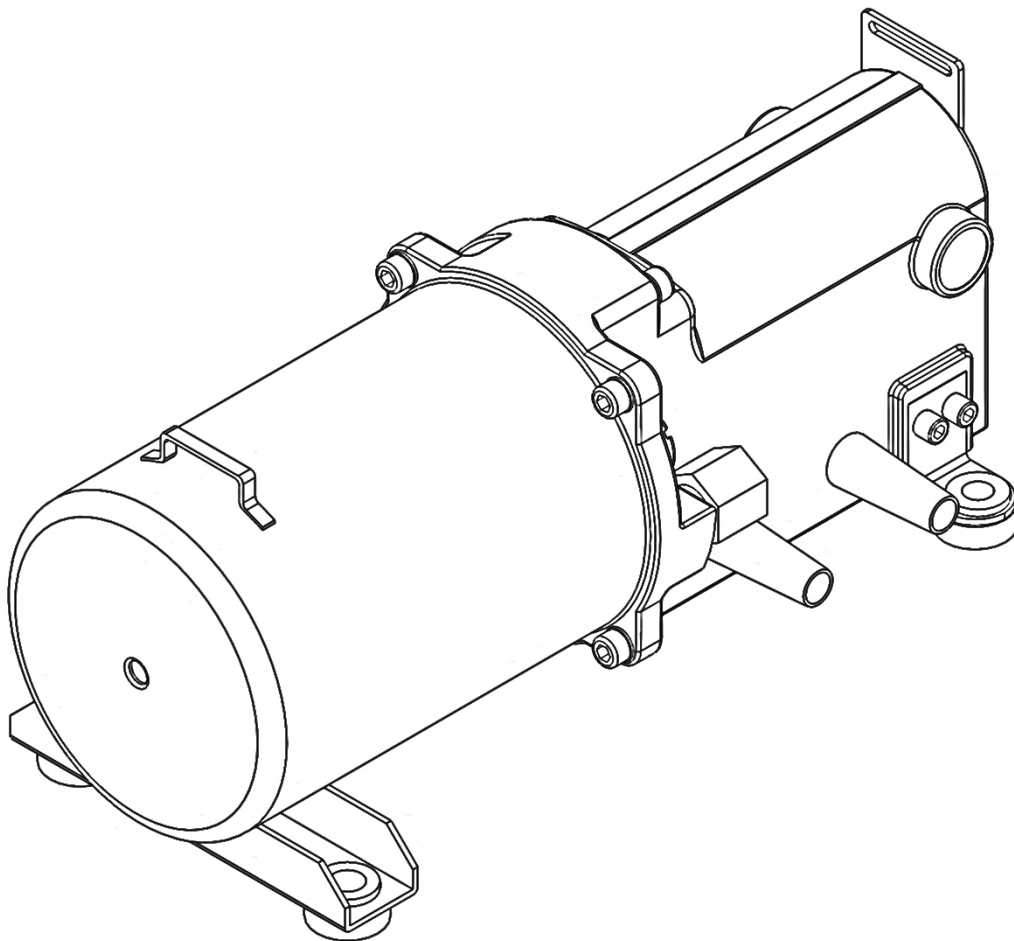

Hi-Force HEP1 series Electric Driven Hydraulic Pumps are designed to operate high pressure hydraulic cylinders and tools with a maximum working pressure of 700Bar. This manual applies to the Hi-Force HEP1 series, Electric Driven Hydraulic Pumps. It contains the latest product information available at the time of publication and approval. Hi-Force reserves the right to make changes to this document at any time without notice.

Table of Contents

1.0 Inspection upon Receipt..... 3

2.0 Safety Precautions 3

 2.1 Introduction 3

 2.2 Work Area Safety..... 3

 2.3 General Hydraulic System Safety Precautions..... 3

 2.4 Hydraulic Pump Specific Safety Precautions 4

3.0 Declaration of Incorporation / Conformity 5

4.0 Specifications 5

4.0 Component Identification 6

5.0 Installation/Setup 6

 5.1 Before First Use..... 6

 5.2 Filling the Pump with Oil 7

 5.3 Electrical Connection 7

 5.4 Hydraulic Connections..... 7

 5.5 Bleeding Trapped Air from the System..... 7

6.0 Operation 8

7 Troubleshooting 8

NOTE: Images contained within this document are for illustrative purposes **ONLY**.

1.0 Inspection upon Receipt

Upon receipt of the product, visually inspect the item for any evidence of shipping damage. Please note: the warranty does not cover shipping damage. Notify the courier immediately if shipping damage is found and refrain from putting the product into service. The carrier is responsible for repair and replacement costs resulting from damage that occurred in transit.

2.0 Safety Precautions

2.1 Introduction



Read and follow all the instructions and safety warnings carefully before handling, installation or use of any hydraulic equipment. Failure to do so could lead to equipment damage, equipment failure, personal injury or even death. Hi-Force will not be held responsible for any damage to the equipment, injury or death resulting from the unsafe use of, lack of maintenance to, or incorrect operation of the product. If in doubt on the correct use of any Hi-Force equipment, contact your nearest Hi-Force office or distributor. Only qualified personnel should be allowed to operate hydraulic equipment. If an operator has not been trained on high-pressure hydraulic equipment and its safe usage, consult your local Hi-Force sales office or distributor who can offer training courses for operators.

2.2 Work Area Safety

- Keep work areas clean and well lit. cluttered spaces and inadequate lighting can result in unnecessary accidents.
- Keep unauthorised persons at a safe distance from the task site.
- **NEVER** use the tools in the presence of inflammable liquids, gases or material.
- **DO NOT** use the tools in potentially explosive atmospheres (ATEX) this tool is **NOT** ATEX approved.

2.3 General Hydraulic System Safety Precautions



WARNING! Failure to observe and obey the following safety precautions could result in property damage, significant personal injury, or death.



- When operating any hydraulic equipment, all operators should ensure that all necessary personal protective equipment (PPE) is worn, as specified by their employer. Steel toe-cap safety shoes, safety glasses/visor, and protective gloves should be worn at all times. All relevant risk assessments should be completed before the use of the equipment.
- Keep hydraulic equipment away from open flames and direct heat.
- **NEVER** handle a pressurised hydraulic hose. Hydraulic oil escaping under pressure from a ruptured hose can penetrate the skin and lead to a significant medical emergency, and in some cases, death. Should this incident occur, seek out medical attention immediately.
- The system operating pressure **MUST NOT** exceed the pressure rating of the lowest-rated component in the system. It is good practice to use a pressure gauge to monitor the entire system.
- Only use hydraulic tools/cylinders in a complete and tested, coupled system. **NEVER** attempt to use a tool/cylinder that is not correctly coupled to its operational pump. **NEVER** pressurise an uncoupled coupler/s.

- **NEVER** attempt to disconnect a hose from a hydraulic system until the systems pressure has been completely released. Doing so can result in that pressure becoming trapped within the system and relieving trapped pressure can be dangerous.
- **NEVER** try to relieve trapped hydraulic pressure in the system by loosening or attempting to remove the coupler. Trapped hydraulic pressure can cause a loosened coupler to dislodge unexpectedly with great force. This action could result in serious personal injury or death, as the coupler could become a projectile and hit operatives in the working area.
- Loosening a coupler under pressure can result in the escape of hydraulic oil at high pressure, which can penetrate the skin and cause significant injury or death.
- **NEVER** use a hammer and punch to unseat a coupler check valve that is under pressure. Doing so could result in the sudden, uncontrolled release of hydraulic oil at high pressure, which could cause significant injury or death.
- Immediately replace any worn or damaged parts using genuine Hi-Force parts only.
- **DO NOT** remove any labels from the product. Replace any damaged or unreadable label immediately.



CAUTION!

Failure to observe and obey the following safety precautions could result in property damage, equipment damage or minor/moderate personal injury.

- **NEVER** lift or carry any hydraulic components by the hose or hoses connected to them.
- Avoid damaging hydraulic hose. **ALWAYS** route hoses to ensure that they are free from sharp bends and kinks. Using a bent or kinked hose will result in severe backpressure, which can lead to hose failure.
- **ALWAYS** operate the system under no-load conditions before the actual operation, to ensure there is no air trapped in the hydraulic circuit.
- Servicing of hydraulic equipment must only be undertaken by a qualified technician.

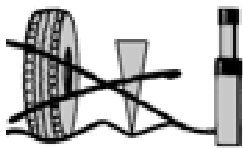

- **DO NOT** drop or place heavy objects on a hydraulic hose, as this may cause internal damage, which could result in rupture of the pressurised hose. A ruptured hose could cause significant damage to components and possible severe injury to personal operating nearby.

2.4 Hydraulic Pump Specific Safety Precautions



WARNING!

Failure to observe and obey the following safety precautions could result in property damage, serious personal injury, or death.

- **NEVER** invert the pump or lay it on its side, either in use, in transport or in storage.
- **DO NOT** weld any items to the pump or modify it in any way from its delivered condition. Your warranty may be invalidated, and it could lead to serious personal injury.
- **NEVER** exceed the maximum rated capacity of any hydraulic cylinder/tool. Hi-Force manufactures its hydraulic pumps to operate at a maximum working pressure of 700 BAR (10,000 PSI). **DO NOT** connect a cylinder/tool with a lower pressure capacity rating to any Hi-Force pump of this model series.
- This pump is not suitable for work which takes place in explosive environments.

⚠ CAUTION! Failure to observe and obey the following safety precautions could result in property damage, equipment damage or minor/moderate personal injury.

- **ALWAYS** stand the pump on a stable level surface during operation.
- **BEWARE** of hot surfaces on the motor. Do not obstruct the flow of cooling air around the motor.
- To protect your warranty, only use the hydraulic oil grade as specified in **Section 5.2**.

3.0 Declaration of Incorporation / Conformity

Hi-Force declares that this product has been tested and complies with the standards set out in the relevant EU directives. The EU Declaration of Incorporation / Conformity is included as Annex A to this instruction document and is supplied with all shipments of this product.

4.0 Specifications

Refer to the identification plate on the pump for model identification.

Table 4.0						
HEP103 Two Stage Electric Driven Hydraulic Mini Pumps						
Model Number	Motor Voltage	Maximum Flow Rate Litres/Min		Valve Type	Usable Oil Cap [Litres]	Weight [kg]
		1 st Stage	2 nd Stage			
HEP1211S	110V-1Ph	2	0.2	2-way	0.8	7.5
HEP1212S	240V-1Ph	2	0.2	2-way	0.8	7.5

4.0 Component Identification

1	Oil Reservoir	5	Oil Filler Cap
2	Electric Motor	6	Power Lead
3	Loop For Carrying Strap	7	Lead To Control Pendant
4	Hydraulic Connection	8	Carbon Brush Cover

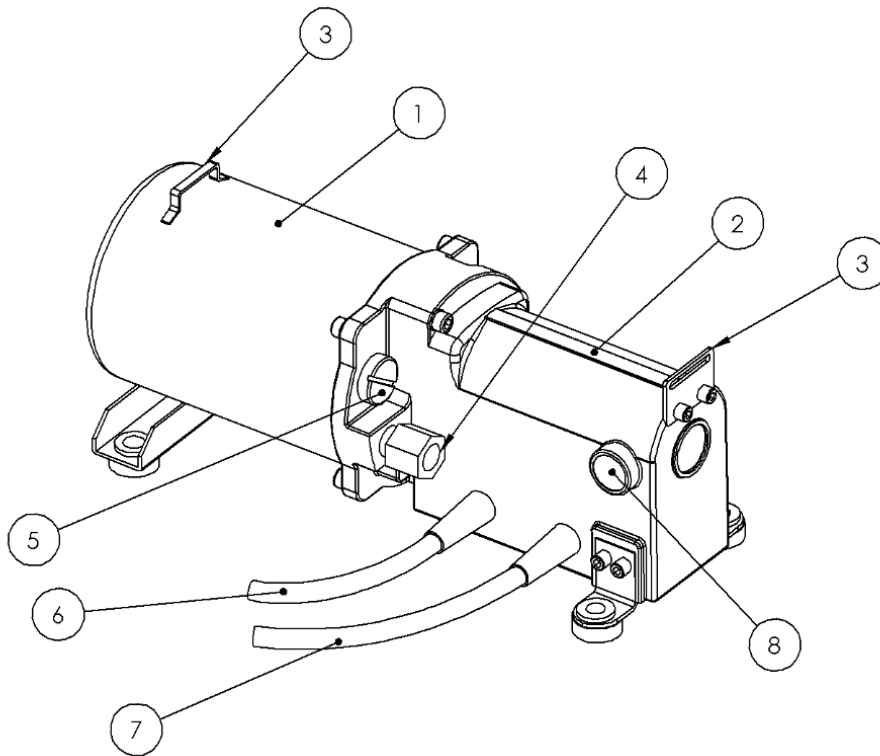

Fig 4.0 – HEP1 Component identification

5.0 Installation/Setup

5.1 Before First Use

1. Visually inspect all components for damage or oil leaks. If shipping damage is found, contact the carrier immediately.
2. Confirm that the power supply is suitable for the pump to be used – see table above. Ensure that the power supply has an earth connection.
3. Confirm oil level in tank. Note that the oil reservoir on the pump is of the sealed type. The filler plug must be kept firmly closed when in use. Oil level must be checked with cylinders fully retracted (or extended for pulling cylinders) Stand pump vertically on end of oil reservoir. Remove filler plug (5) and check that oil level. Replenish as required with Hi-Force HFO46 oil. Replace plug and tighten firmly taking care not to damage O-ring.
4. Make hydraulic connection to cylinder using only hoses suitable for 700 bar operating pressure. Outlet port threads are 3/8" NPT. All threads should be sealed with PTFE tape or pipe sealant.

5.2 Filling the Pump with Oil

IMPORTANT: The HEP1 series of hydraulic pumps uses **ISO46 Grade Hydraulic Oil**.

- Stand the pump on a firm, level surface.
- Remove the oil filler cap (5) from the pump.
- Fill the reservoir with clean, high quality ISO46 hydraulic oil via the oil filler breather port.
- Refit the oil filler plug.

IMPORTANT: Only add oil to the reservoir when the connected cylinder/tool is fully retracted. Failure to do so will result in the system containing more oil than the reservoir can hold.

5.3 Electrical Connection

Before making an electrical connection, refer to table 4.0 for voltage and current requirements. Once satisfied that the supply is suitable, proceed with making the electrical connection.

NOTE: Supply voltages vary from country to country. Hi-Force pumps will operate within the normal voltage tolerance ranges, but in extreme cases where they are operated for long periods at high pressures and in low voltage conditions, the motor may overheat and shut down.

NOTE: A common cause of pump failure is the use of long extension cables to connect the pump to the mains supply. The pump should be situated as close as possible to the wall outlet.

5.4 Hydraulic Connections

Connect the hydraulic hose/s between the cylinder/tool and the pump, ensuring that the coupling/s (if fitted) are **fully hand-tightened only**. **NEVER** use wrenches in an attempt to connect the coupling/s. Incorrectly connected coupling/s are one of the most common causes of faulty operation.

IMPORTANT: Make sure that all coupler threads are fully engaged.

5.5 Bleeding Trapped Air from the System

⚠ WARNING! The bleeding of trapped air from a hydraulic system must only be performed by qualified personnel who have been trained and are competent to do so.

Cylinders, tools, and hoses are not always completely filled with oil when new. For safe and efficient operation, trapped air must be removed from the system. The follow procedure must be carried out with the cylinder/tool connected to the pump, but not operating under load.

To remove air from the system, proceed as detailed below:



Fig 5.1

- Make sure the oil filler breather plug is fitted.
- With all hydraulic connections made, position the cylinder/tool below the level of the hydraulic pump, as illustrated in figure 5.1.

Single-Acting: With smaller single-acting cylinders, position them with the piston facing downward, as illustrated in figure 5.1.

- Using the pump, fully advance and retract the cylinder/tool piston several times until the operation is smooth. (See section 6.0 for details of pump operation).

NOTE: When longer hoses are used (especially in the case of smaller capacity cylinders), the above procedure may not remove all the air from the system. In these cases, contact your Hi-Force representative for advice on pre-filling hoses with hydraulic oil.

6.0 Operation

1. Connect pump to power supply.
2. Depress the ON button on the control pendant to start the motor and advance the cylinder/ tool. When the button is released the motor stops, and the pump will maintain pressure to hold the load in place.
3. To retract the cylinder, depress the OFF button on the pendant to return oil to tank. **Note:** The cylinder will retract fully even if the button is released.
4. If it is required to stop the cylinder retracting part way through its travel, then it will be necessary to press the ON button once more to build up pressure again.

7.0 Maintenance

Use only Hi-Force HFO46 oil to keep the reservoir topped up. Ensure that connected cylinders are fully retracted before checking oil level otherwise reservoir may become pressurised and damaged.

The Oil should be changed completely after approximately 300 hours working time. To drain the oil, remove the filler plug and tip the oil out. Dispose of used oil in accordance with environmental procedures.

The oil reservoir is sealed but when connecting new hoses and cylinders air can become trapped in the reservoir causing intermittent operation or the pump not to deliver oil. To remove the air, fully retract cylinder. Stand pump vertically with filler plug (5) uppermost. Remove the filler plug and top up with oil. Replace filler plug and operate pump several times in a vertical position.

If the pump will still not deliver oil stand the pump level on its feet and insert a smooth round ended rod through the hole in the rear end of the reservoir and push the rubber bladder inwards by about 30mm while operating the motor. Take care not to damage the rubber bladder.

Carbon brush replacement. The brushes will wear down in use and eventually cause the motor to stop. Replace with genuine brushes only. Disconnect from power supply. Remove the two rubber covers (8) and remove fitting screws so that brushes can be removed and replaced. Replace covers afterwards.

8.0 Troubleshooting

Hi-Force HEP103 electric driven hydraulic pumps should be serviced and repaired only by authorised Hi-Force repair centres. The following table gives possible causes and solutions for common problems.

TROUBLESHOOTING GUIDE		
Problem	Possible Cause	Solution
1. Pump will not start.	a. Power not connected.	Connect power.
	b. Damaged power cord.	Repair or replace power cord.
	c. Circuit breaker tripped.	i. Reset Circuit breaker. ii. Ensure breaker is adequately rated.
	d. Damaged pendant.	Contact your local Hi-Force office/distributor.
	e. Blown fuse.	Replace blown fuse.
	f. Burnt out motor.	Contact your local Hi-Force office/distributor.

2. Motor stalls before full operating pressure is reached.	a. Low supply voltage.	i. Use heavier gauge extension cord. ii. Turn off excess electrical loads.
3. Pump runs but will not build up to full operating pressure.	a. Reservoir oil filler plug has not been loosened.	loosen oil filler plug as per section 5.1
	b. Low oil level.	Add oil as per section 5.2.
	c. External oil leak in system.	Contact your local Hi-Force office/distributor.
4. Noisy Operation	a. Air trapped in the system.	Bleed air from the system as per section 5.5
	b. Low oil level	Add oil as per section 5.2
5. Pump builds to full pressure, but cylinder/tool does not advance/operate.	a. Advance or return flow line to cylinder/tool restricted or blocked.	Check couplers (if fitted) for full engagement.
6. Pump running hot.	a. Low oil level.	Add oil as per section 5.2.
	b. Advance or retract flow restricted.	Check couplers (if fitted) for full engagement.
	c. High pressure leakage at pump.	Contact your local Hi-Force office/distributor.
7. Cylinder/tool not functioning correctly.	a. Cylinder/tool incorrectly connected to pump.	Check for correct system setup. Check couplers (if fitted) for full engagement
	b. Pump solenoid faulty.	Contact your local Hi-Force office/distributor.
	c. Cylinder/tool fault.	See cylinder/tool's troubleshooting guide or contact your local Hi-Force office/distributor.
	d. Low oil level	Add oil as per section 5.2.
	e. Air trapped in the system	Bleed air from the system as per section 5.5
8. Cylinder/tool will not retract.	a. Valve malfunction.	Contact your local Hi-Force office/distributor.
	b. Return flow line restricted or blocked.	i. Check couplers (if fitted) for full engagement. ii. Run motor while retracting cylinder/tool.
10. Gauge displays no pressure reading.	a. faulty gauge.	Contact your local Hi-Force office/distributor
	b. pump will not build pressure.	Contact your local Hi-Force office/distributor.

Head Office:

Hi-Force Limited

Prospect Way, Daventry

Northamptonshire NN11 8PL

United Kingdom

Tel: + 44 1327 301000 | Fax: + 44 1327 706555

www.hi-force.com

Regional Offices:

For information on our offices worldwide, scan the below QR code

