

This 'Original instructions' document assumes that the operator carrying out any operation with this product is trained and competent to do so. This manual does not attempt to cover all details or variations in the equipment. Nor does this manual claim to provide for every possible contingency met in connection with the installation, operation, or maintenance thereof. Should further information be desired, or should a particular problem arise which is not covered in sufficient detail, the matter should be referred to Hi-Force.

## OPERATING INSTRUCTION MANUAL

### TPE-AM | ELECTRIC DRIVEN TORQUE WRENCH PUMP – WITHOUT AUTO CYCLE

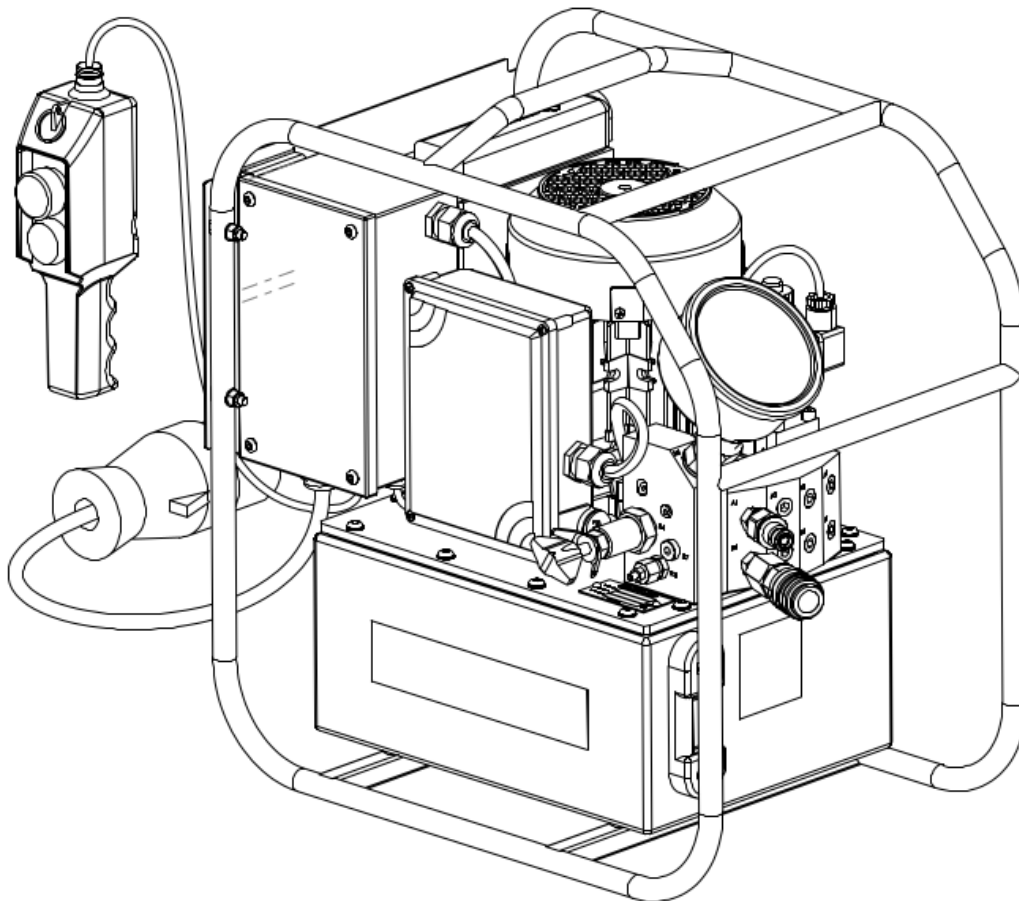

Hi-Force TPE-AM series analogue Driven Torque Wrench Pumps are premium pumps designed for use with Hi-Force Hydraulic Torque Wrenches. TPE-AM Pumps can be used to power up to 4 torque wrenches simultaneously (all operating at the same pressure). Output pressure is fully adjustable and can be set to any value up to a maximum working pressure of 700 bar (10,000 psi). This manual applies to the Hi-Force TPE-AM analogue, Electric Driven Torque Wrench Pumps Only. It contains the latest product information available at the time of publication and approval. Hi-Force reserves the right to make changes to this document at any time without notice.

**Table of Contents**

**1.0 Inspection upon Receipt .....2**

**2.0 Safety Precautions.....3**

**3.0 Declaration of Incorporation/Conformity .....6**

**4.0 Component Identification.....7**

**5.0 Installation/Setup .....9**

**6.0 Operation ..... 16**

**7.0 Maintenance and Storage.....20**

**8.0 Specifications.....21**

**9.0 System Components/Accessories .....22**

**10.0 Pressure Conversion Table.....23**

**11.0 Troubleshooting.....24**

**1.0 Inspection upon Receipt**

Upon receipt of the product, visually inspect the item for any evidence of shipping damage. Please note: the warranty does not cover shipping damage. Notify the courier immediately if shipping damage is found and refrain from putting the product into service. The carrier is responsible for repair and replacement costs resulting from damage that occurred in transit.

**NOTE:** Images contained within this document are for illustrative purposes **ONLY**.

## 2.0 Safety Precautions

### 2.1 Introduction



Read and follow all the instructions and safety warnings carefully before handling, installation or use of any hydraulic equipment. Failure to do so could lead to equipment damage, equipment failure, personal injury or even death. Hi-Force will not be held responsible for any damage to the equipment, injury or death resulting from the unsafe use of, lack of maintenance to, or incorrect operation of the product. If in doubt on the correct use of any Hi-Force equipment, contact your nearest Hi-Force office or distributor. Only qualified personnel should be allowed to operate hydraulic equipment. If an operator has not been trained on high-pressure hydraulic equipment and its safe usage, consult your local Hi-Force sales office or distributor who can offer training courses for operators.

### 2.2 Work Area Safety

- Keep work areas clean and well lit, cluttered spaces and inadequate lighting can result in unnecessary accidents.
- Keep bystanders clear of any hydraulic tool activity. Personnel working in close-range should be made aware of all high-pressure work before commencing.

### 2.3 Electrical Safety Precautions

- Electrical power plugs / sockets **MUST** match the power source outlet socket. Never modify electrical power plugs or tool / equipment electrics.
- **DO NOT** abuse cabling. **DO NOT** use electric cables to carry, move or disconnect tools. Make sure electrical cabling is clear of heat sources, sharp edges or moving parts.
- When using the unit outdoors, use a suitably rated extension lead (if required) to reduce the risk of electric shock.

### 2.4 General Hydraulic System Safety Precautions



**WARNING!** Failure to observe and obey the following safety precautions could result in property damage, significant personal injury or death.



- When operating any hydraulic equipment, all operators should ensure that all necessary personal protective equipment (PPE) is worn, as specified by their employer. Steel toe-cap safety shoes, safety glasses / visor, ear protection, and protective gloves should be worn at all times. All relevant risk assessments should be completed before the use of the equipment.
- Keep hydraulic equipment away from open flames and direct heat.
- **NEVER** use a coupler as a tool handle, especially if the system is pressurised.
- Inspect hoses regularly for damage and wear.

- **NEVER** use hoses that are frayed, kinked, abraded, or leaking.
- **NEVER** handle a pressurised hydraulic hose. Hydraulic fluid escaping under pressure from a ruptured hose can penetrate the skin and lead to a significant medical emergency, and in some cases, death. Should this incident occur, seek out medical attention immediately.
- Seek medical attention immediately if a hydraulic injection injury (no matter how minor) occurs.
- The system operating pressure **MUST NOT** exceed the pressure rating of the lowest-rated component in the system.

**Good Practice:** Use a pressure gauge to monitor the entire system.

- Only use hydraulic tools/cylinders in a complete and tested, coupled system. **NEVER** attempt to use a tool/cylinder that is not correctly coupled to its operational pump.

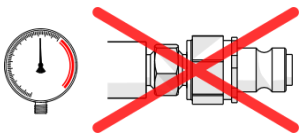

- **NEVER** pressurise an unconnected male coupler/s.

- **NEVER** attempt to disconnect a hose from a hydraulic system until the system's pressure has been completely released. Doing so can result in that pressure becoming trapped within the system and relieving trapped pressure can be dangerous.
- **NEVER** try to relieve trapped hydraulic pressure in the system by loosening or attempting to remove the coupler. Trapped hydraulic pressure can cause a loosened coupler to dislodge unexpectedly with great force. This action could result in serious personal injury or death.
- Loosening a coupler under pressure can result in the escape of hydraulic oil at high pressure, which can penetrate the skin and cause significant injury or death.
- **NEVER** use a hammer and punch to unseat a coupler check valve that is under pressure. Doing so could result in the sudden, uncontrolled release of hydraulic oil at high pressure, which could cause significant injury or death.
- **NEVER** attempt to solve, or clean-up leaks in the system while the system is pressurised.
- Immediately replace any worn or damaged parts using genuine Hi-Force parts only.
- **DO NOT** use any hydraulic equipment if you are under the influence of alcohol, drugs or medication. Lack of attention whilst operating high-pressure hydraulic tools can result in personal injury or death.



## CAUTION!

Failure to observe and obey the following safety precautions could result in property damage, equipment damage or minor/moderate personal injury.

- **NEVER** lift, carry or move any hydraulic components by the hose or hoses connected to them.

- Avoid damaging hydraulic hoses. **ALWAYS** route hoses to ensure that they are free from sharp bends and kinks. Using a sharply bent or kinked hose will result in severe back-pressure, which can lead to hose failure.
- **NEVER** use a coupler/s to lift, carry or position a tool.
- Servicing of hydraulic equipment must only be undertaken by a qualified technician.

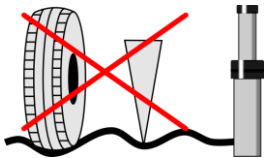

- **DO NOT** drop or place heavy objects on a hydraulic hose, as this may cause internal damage, which could result in rupture of the pressurised hose. A ruptured hose could cause significant damage to components and possible severe injury to personal operating nearby.

- **DO NOT** let familiarity gained with any hydraulic tools allow you to become complacent. Complacency with any tooling can result in a lack of discipline toward working guidelines and safety principles.
- **DO NOT** remove any labels from the product. Replace any damaged or unreadable labels immediately.
- Avoid loose clothing and jewellery that could get caught in moving parts, tie back long hair.

## 2.5 Hydraulic Pump Specific Safety Precautions



**WARNING!** Failure to observe and obey the following safety precautions could result in property damage, serious personal injury or death.

- **NEVER** exceed the maximum rated pressure of any hydraulic equipment. Hi-Force manufactures its TPE-AM hydraulic pumps to operate at a maximum working pressure of 700 bar (10,000 psi). **DO NOT** connect hydraulic torque equipment with a lower pressure capacity rating to any Hi-Force pump of this model series.
- Make sure all equipment connected to the pump is in good working condition.
- **NEVER** invert the unit or lay it on its side, either in use, in transport or in storage.
- **DO NOT** weld any items to the pump unit or modify it in any way from its delivered condition. Your warranty may be invalidated, and it could lead to serious personal injury.
- **ALWAYS** ensure there is clear communication between the pump operator and the tool operator/s. **DO NOT** operate the pump unless the tool operator/s indicates it is safe to do so.

Take extra care when multiple tools are being operated by a single pump. Make sure all tool operators have given the go-ahead before operating the pump.

- **NEVER** attempt to connect or disconnect a tool/hose/component while the system/pump is under pressure.
- **NEVER** operate the pump without both hydraulic hoses and a suitable torque wrench connected to it.

- **NEVER** leave a pressurised system unattended. If you must leave the area, release the pressure and ensure the hydraulic relief valve on the pump is fully open.
- **ALWAYS** disconnect the pump from the power supply when carrying out maintenance or adjustments (except pressure relief valve adjustments).
- This pump is **NOT ATEX RATED** i.e. **NOT** suitable for work which takes place in explosive environments.



## **CAUTION!**

**Failure to observe and obey the following safety precautions could result in property damage, equipment damage or minor/moderate personal injury.**

- **ALWAYS** stand the pump on a stable, level surface during operation.
- **BEWARE** of hot surfaces on the motor. **DO NOT** obstruct the flow of cooling air around the motor.
- To protect your warranty, only use the hydraulic oil grade specified in Section 5.2.

### **3.0 Declaration of Incorporation/Conformity**

Hi-Force declares that this product has been tested and complies with the standards set out in the relevant EU directives. The EU Declaration of Incorporation/Conformity is included as Annex A to this instruction document and is supplied with all shipments of this product.

## 4.0 Component Identification

1	Oil Reservoir	6	Tool Advance Coupler (700 bar maximum)
2	Electric Motor	7	Tool Retract Coupler (90 bar maximum)
3	Oil Cooling Heat Exchanger	8	Oil Temperature/Level Gauge
4	'Solenoid Valve' Manual Override Button	9	Oil Filler/Breather Cap
5	Oil Pressure Gauge	-	

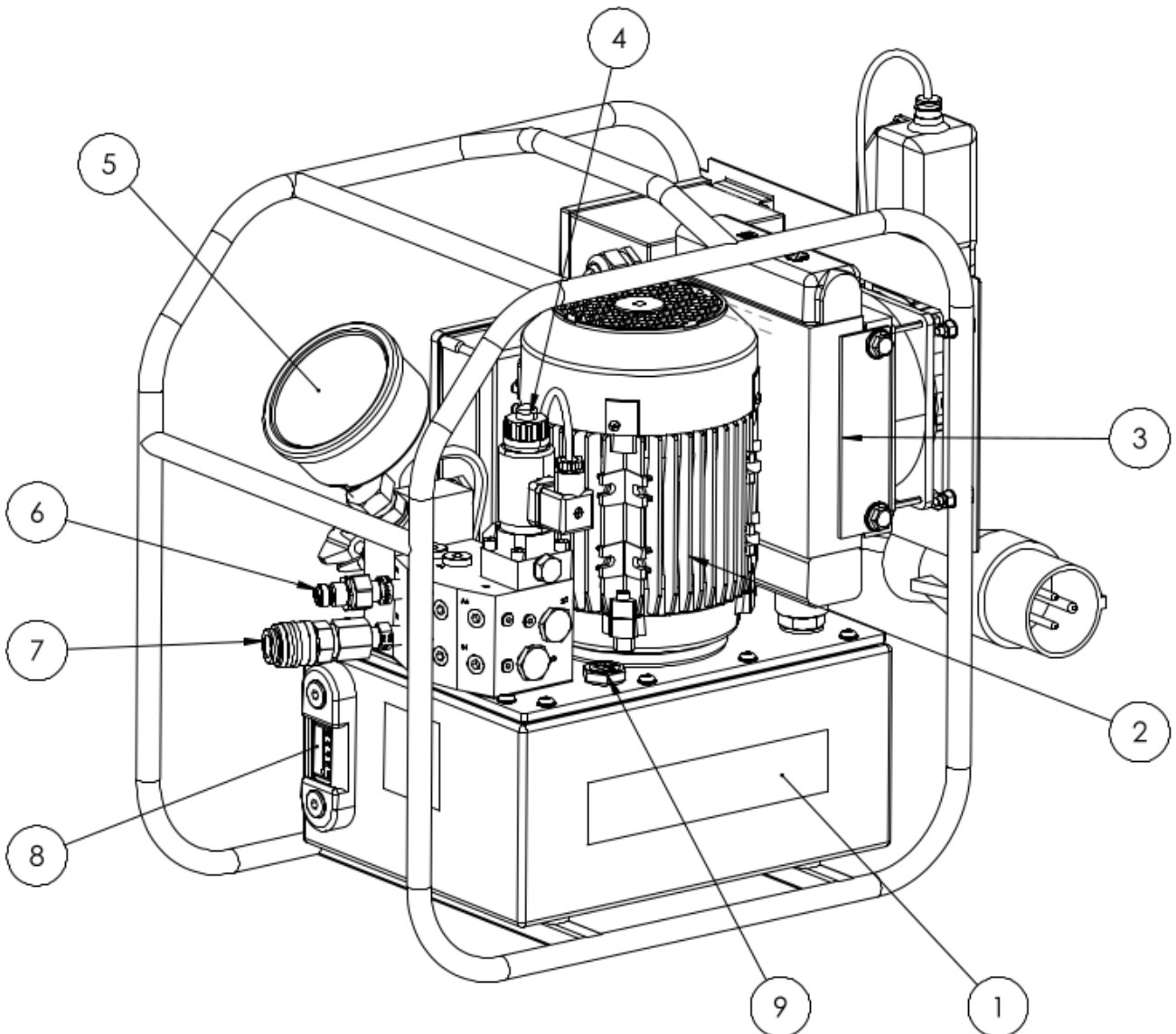

Figure 4.1: Component Identification

10	Electrical Control Box	15	Heat Exchanger Fan
11	Emergency Stop Button	16	Drain Plug
12	Adjustable Pressure Relief Valve with Locking Wing Nut	17	Pendant
13	Multi-Outlet 4-Way Split-Block *	18	Advance Button
14	Roll Frame	19	Motor Start/Stop Button

\* See Section 5.4

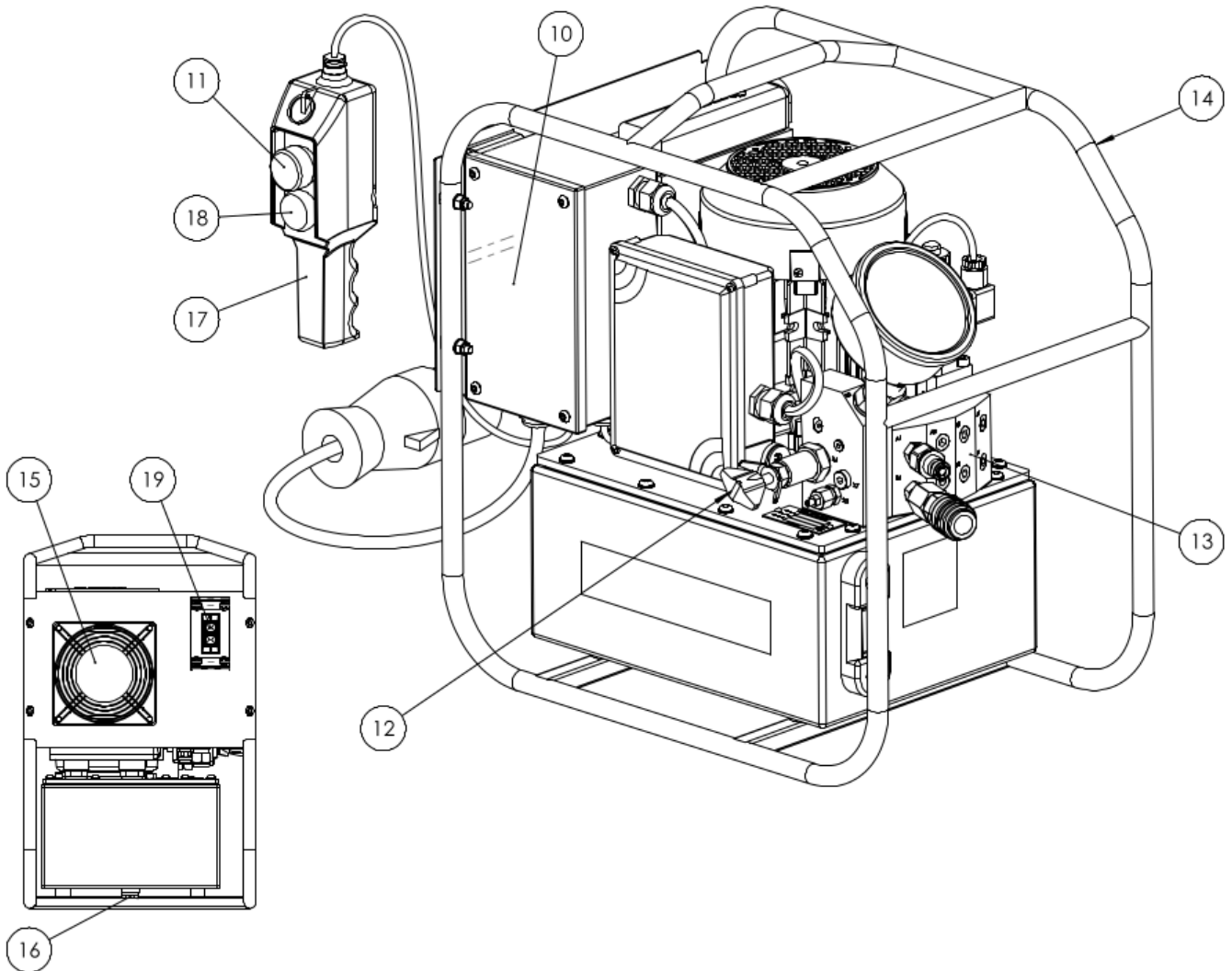

Figure 4.2: Component Identification



## 5.0 Installation/Setup

### 5.1 Before First Use / Preparation

1. Immediately after unpacking, examine the unit for signs of transit damage and if found contact the shipping company.
2. Establish the oil level in the oil reservoir (1) using the oil level gauge (8). Depending on the shipping method used, the reservoir may either be supplied full or empty. If the reservoir is empty, it must be correctly filled before use (See section 5.2). If the reservoir was supplied full of oil, no further action is required.

**IMPORTANT:** Running the pump without oil will result in damage.

### 5.2 Filling the Reservoir with Oil

**IMPORTANT:** The TPE-AM pump uses **ISO46 Grade Hydraulic Oil**.

- Stand the Pump on a firm, level surface.
- Remove the filler cap (9) from the filler breather.
- Fill the reservoir with clean, high-quality ISO46 hydraulic oil via the filler breather until the oil level reaches the maximum level on the oil level gauge (8).
- Replace the filler cap (9) on the filler breather.

**⚠ CAUTION!** Ensure the oil level does not fall below the minimum level. Running the pump without oil will result in damage. (See section 7)

**IMPORTANT:** Only add oil to the reservoir when the attached tool is fully retracted. Failure to do so may result in the system containing more oil than the reservoir can hold.

**NOTE:** More hydraulic oil can be added to the reservoir to assist with cooling if required, but not more than 10mm above the max oil level mark on the gauge (8).

## 5.3 Hydraulic Connections

### ⚠ WARNING!

TPE-AM pumps are designed for use with double-acting torque tools (powered in both the advance and retract directions) and **MUST** be connected to the tool/s via both, the advance and retract couplers. **DO NOT** pressurise the pump/system if there are any disconnected couplers in the system.

- **ALWAYS** use Hi-Force HTWH hoses to make connections.
- Hi-Force TPE-AM Torque Wrench Pumps are fitted with dual flat-face quick-connect couplers.
- Make sure both coupler halves are clean before connecting.

### ⚠ WARNING!

If you are **NOT** using a Hi-Force Torque Wrench with the pump, or if the wrench or hoses have been modified, make sure that the wrench is connected correctly so that the male high-pressure advance coupler (6) is connected to the advance port on the tool. Failure to do so may result in leakage, tool damage or personal injury.

### 5.3.1 Connections (See figure 5.1)

Connections between couplers are made by simply [1] pressing the male coupler into the female coupler until [2] the locking collar springs forward and locks the couplers together.

A gentle tug on the hose should be enough to make sure the hose is correctly connected.

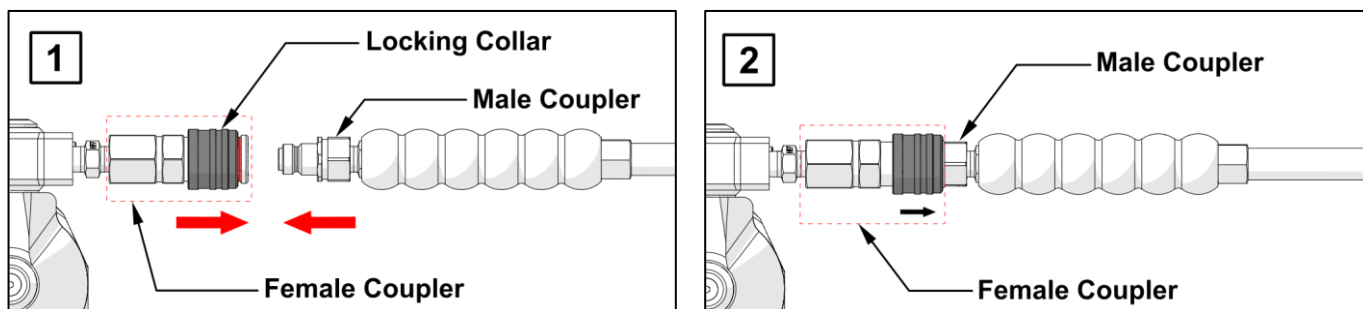

Figure 5.1: Hydraulic Connections

### 5.3.2 Disconnections (See figure 5.2)

### ⚠ WARNING!

Always make sure the pump is switched off and pressure has been fully released before disconnections are made.

To disconnect couplers; [1-1] twist the locking collar on the female coupler in the direction of arrow and [1-2] pull back toward the female coupler body. [2] With the locking collar retracted, pull the male and female couplers apart. Fit dust caps after disconnections are made.

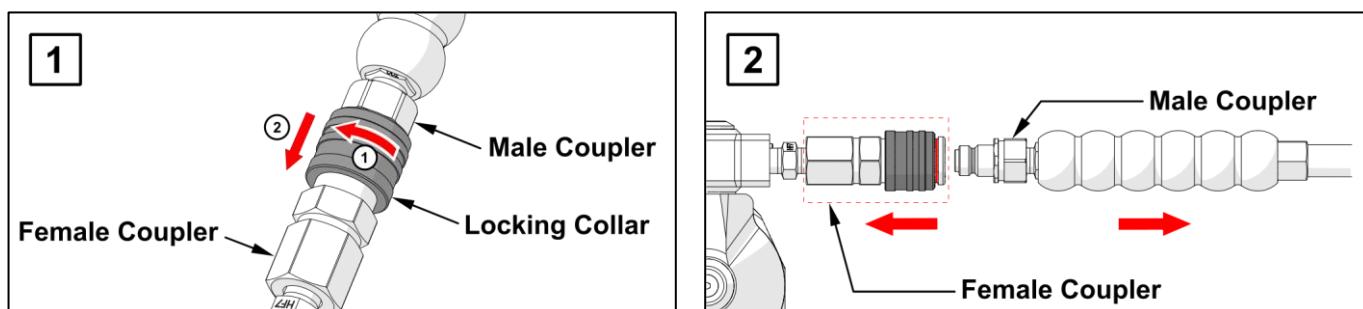

Figure 5.2: Hydraulic Disconnections

### 5.3.3. Connecting a Torque Wrench to the Pump

- Connect the female coupler on the red hose to the male advance coupler (6) on the pump.
- Connect the male coupler on the black hose to the female retract coupler (7) on the pump.

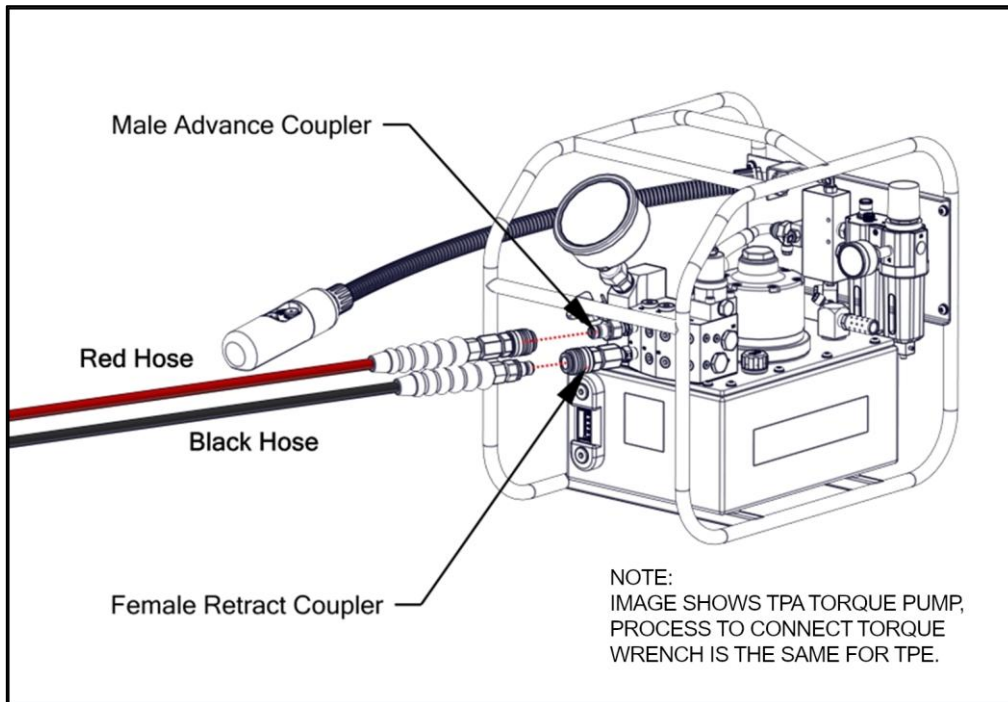

Figure 5.3: Connecting to the Pump

- Connect the free end of the red hose to the advance port on the torque wrench.
- Connect the free end of the black hose to the retract port on the torque wrench.

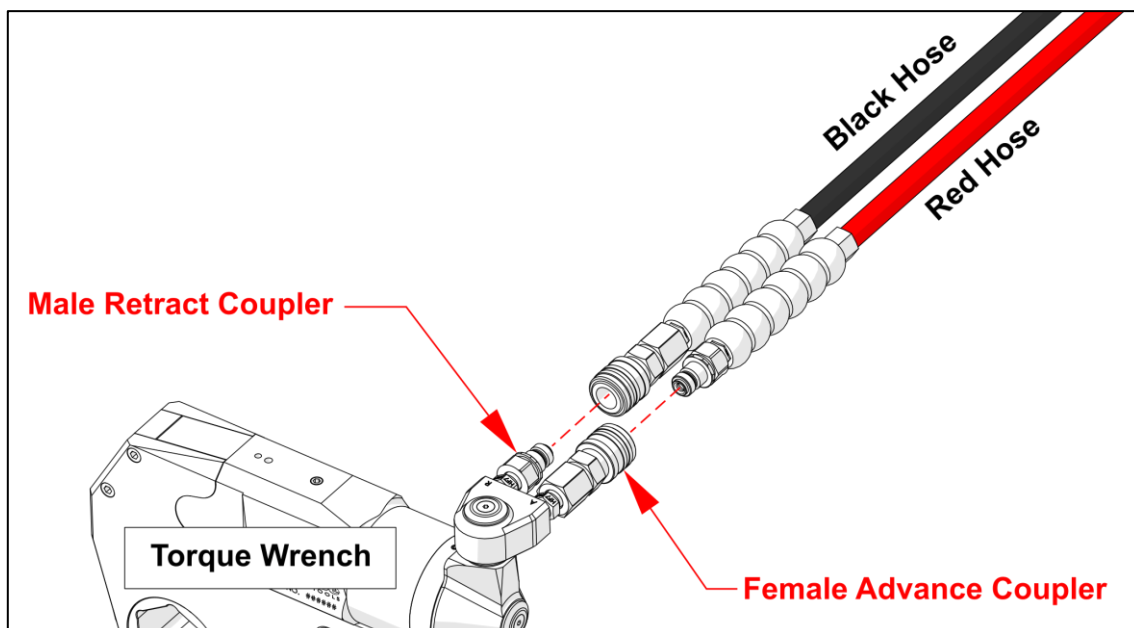

Figure 5.4: Connecting the Torque Wrench

## 5.4 Connection of Additional Torque Wrenches

Hi-Force TPE-AM Pumps are equipped with additional ports allowing for up to 4 Torque wrenches to be driven simultaneously (all operating at the same pressure).

This feature can be useful for even tightening of large joints. However, it must be noted that multiple torque wrenches will operate slower than a single torque wrench would, so this is not necessarily a time-saving method.

To make use this feature,

- Switch off the pump and disconnect from the power supply.
- Remove the relevant blanking plugs from the outlet split block (13) and fit the required number of extra coupler pairs. **ALWAYS** fit the male coupler to the top port and the female coupler to the bottom port to ensure correct torque wrench connection. (See figure 5.5)

**NOTE:** The ports are 1/4" NPT, and a suitable thread sealant or PTFE Tape must be applied to the coupler threads before they are fitted.

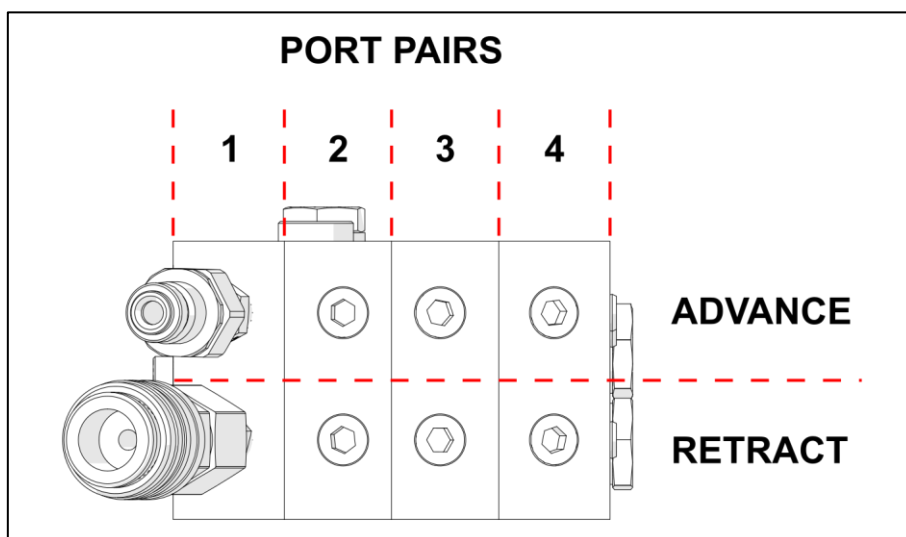

*Figure 5.5: Split Block Port Pairs*

Hi-Force can supply the following torque coupler sets:

TP-CS1: Torque coupler set to convert TPE-AM pump from 1 outlet to 2 outlets.

TP-CS2: Torque coupler set to convert TPE-AM pump from 1 outlet to 3 outlets.

TP-CS3: Torque coupler set to convert TPE-AM pump from 1 outlet to 4 outlets.

## 5.5 Electrical Connection

Before making an electrical connection, refer to the data plate located on the motor (2) for voltage and current requirements. Once satisfied the supply is suitable, an electrical connection can be made.

**NOTE:** Supply voltages vary from country to country. Hi-Force pumps will operate within the normal voltage tolerance ranges, but in extreme cases where they are operated for long periods at high pressures and in low voltage conditions, the motor may overheat and shut down.

**NOTE:** A common cause of pump failure is the use of long extension cables to connect the pump to the mains supply. The pump should be situated as close as possible to the power source.

## 5.6 Priming the Pump

The pump is self-priming and will not need to be primed before use.

## 5.7 Bleeding Trapped Air from the System

Torque wrenches and hoses are not always filled with oil when new. Hi-Force HTWH hoses are supplied pre-filled with oil, but NEVER assume that there are no air pockets in a hose. Air trapped in the system will lead to erratic operation of the torque tool. For safe and efficient operation, trapped air must be removed from the system. The following procedure must be carried out with a torque wrench connected to the pump, but **NOT** fitted on a bolt.

Hi-Force uses superior quick-connect couplers on its torque tools and hoses, which admit very little air into the system when connections and disconnections are made. However, for best performance, carry out the below process each time hoses or tools are exchanged.

To remove air from the system, proceed as detailed below:

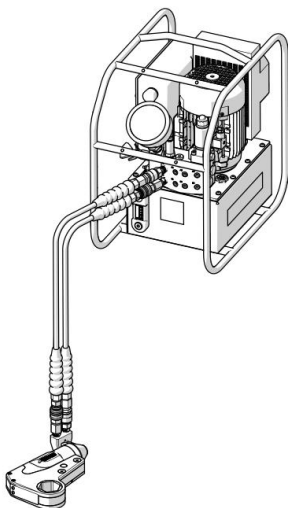

- Position the tool below the level of the hydraulic pump (as illustrated).
- Connect the pump to a power supply. (The motor will not start until the "Motor Start" button (19) is pressed).
- Twist the "STOP" Button (11) clockwise to ensure they are released.

**NOTE:** The tool may slowly perform a retracting motion. This is normal but does not always occur, it will depend on a few factors.

- Ensure the pressure relief valve (12) is fully open (wound anti-clockwise).
- Press the 'Motor Start' button (18) once, to turn on the pump.
- Press and hold the 'Advance' button on the control pendant (18). The tool may stay stationary or advance slowly depending on the relief valve setting.
- Set the adjustable relief valve (12) to approx. 100 bar. The tool will advance to its full stroke. If the tool retracts, then the hoses are connected incorrectly and need to be swapped over at the tool couplers. **(Function test)**

- Release the 'Advance' button on the control pendant. The tool will automatically retract, and the gauge pressure will build up to between 80 & 90 bar.
- Repeat the advance and retract cycle at least 10 times to fully purge the air from the system.
- Visually inspect the system for leaks. **(Low-Pressure leak test)**

 **WARNING!** With the motor running the retract hose/s still contains 80 - 90 bar pressure.  
**DO NOT TOUCH.**

**NOTE:** When longer hoses are used (greater than 5m), the above procedure may not remove all the air from the system. In these cases, contact your Hi-Force representative for advice on pre-filling hoses with hydraulic oil.

- Press and hold the 'Advance' button again. While doing so, adjust the relief valve by turning the knob clockwise until the maximum working pressure (700 bar) is reached. The pressure can be reduced by turning the knob anti-clockwise. The pressure setting can be locked at the desired value by tightening the wing nut under the adjusting knob clockwise.
- Cycle the pump 2-3 times to full pressure making sure both the pump and connected tool/s operate smoothly through the entire pressure range.
- Visually inspect the system for leaks. **(High-Pressure leak test)**

 **WARNING!** With the motor running the retract hose/s still contains 80-90 bar pressure.  
**DO NOT TOUCH.**

- Switch off the pump unit by pressing the 'Motor Stop' button (19) on the 'Electrical Control Box' (10) and check the tool and connections for any leaks. If leaks are found, these **MUST** be rectified before commencing with any torque operation.

## 5.8 System Leak Test & Function Test

**NOTE:** These tests are performed as part of the process detailed in section 5.7 and need not be repeated if the full process described in section 5.7 has been performed.

### Low-Pressure Leak Test & Function Test

**IMPORTANT:** A system leak test should be performed each time a coupler/s is disconnected, and new connections are made. Paying special attention to connection points and new components introduced to the system. (Hoses, tools etc.)

With all hoses and tools correctly connected to the pump and the pump connected to the power supply, perform a low-pressure leak test.

- Make sure the pressure relief valve (12) is in its fully open position (wound anti-clockwise).
- Switch on pump by pressing the 'Motor Start' button (19) on the "Electrical Control Box" (10) once.
- Press and hold the 'Advance Button' on the control pendant. (At this stage the pressure gauge should read zero and the connected tool should not advance).
- While holding the 'advance button' in, slowly turn the pressure relief knob clockwise and monitor the pressure gauge. The pressure will slowly start to build, and the torque wrench will begin to advance.

Continue until the gauge reads approximately 100 bar.

- With the pressure holding steady around 100 bar, perform a visual inspection of the tool/s, hoses, and couplers for any signs of oil leakage.

**⚠ WARNING! DO NOT** touch the hoses or couplers while the system is pressurised.

- If a leak/s is found, depressurise the system completely before attempting to repair, resolve or inspect a leaking component. **DO NOT** wipe away excess oil from any component while the system is still pressurised.
- If no leaks are found during the leak test it is safe to continue.

### High-Pressure Leak Test

With the leak test completed and before connecting the tool to a nut/bolt, perform a function test to ensure the tool and pump operate correctly through their entire pressure range.

A function test should be performed at the beginning of each work shift and should be repeated for every new tool connected to the pump, during the shift.

- While continuing to hold the pump in advance mode, adjust the pressure relief valve (clockwise) until the pressure gauge reads 700 bar.
- Cycle the pump 2-3 times to full pressure making sure both the pump and connected tool/s operate smoothly through the entire pressure range.
- Visually inspect the system for leaks.

If any issues are found during the function test, they must be investigated and resolved before putting the pump/tool into use.

## 6.0 Operation

Hi-Force TPE-AM Torque Wrench Pumps are used to power double-acting Hydraulic Torque Wrenches. Make sure you read this manual in conjunction with the Torque Wrench's operating instruction manual to ensure correct and safe operation of all hydraulic equipment in the system.

Before applying pressure to the system make sure you observe the following points

- You are aware of the correct operation of the Torque Wrench/s.
- You are aware of the maximum working pressure of the Torque Wrench/s.
- You are aware of the required working pressure/s that must be applied to the Torque Wrench/s.
- You have read and fully understood the torquing sequence and procedure.
- You have performed the relevant risk assessment/s and have a method statement (safe system of work) for all operators to follow.

 **WARNING!** With the motor still running the retract hose/s still contains 80 - 90 bar pressure. **DO NOT TOUCH.**

### 6.1. Preparing the Pump for Operation

1. Check that the mains power supply matches the voltage displayed on the motor data plate.
2. Connect the torque wrench/s to the pump as per section 5.3.
3. Turn the pressure relief valve (12) fully anti-clockwise (fully open position).
4. Connect the pump to the power supply.
5. If necessary, bleed trapped air from the system as per section 5.7.
6. Perform system leak & function tests as per section 5.8.



## 6.2. Setting the Pressure (Torque)

Before setting the pump pressure it is necessary to determine what pump pressure will result in the torque value required.

Use the tool-specific pressure-torque conversion chart provided with the torque wrench to determine the pump pressure that corresponds to the required torque value.

**⚠ CAUTION!** The procedure for setting the pump pressure **MUST** be carried out with the torque tool attached to the pump but **NOT** fitted onto a nut or bolt.

The procedure for setting the pump pressure is as follows:

1. Loosen the wing nut [1] below the adjustable relief valve knob and turn the relief valve knob [2] fully anti-clockwise.
2. Turn the pump ON by pressing the 'Motor Start' button once.
3. Press and hold down the 'advance button' on the pendant. The tool will advance and stop at its maximum stroke, this is correct.
4. While holding the pump in advance mode, slowly turn the relief valve knob [2] clockwise and watch as the pump pressure on the gauge rises.

When the pressure reaches your desired value, stop turning the knob and allow the gauge to settle.

5. If the pressure continues to rise above the desired pressure, release the advance button and back the pressure off slightly, to below the target pressure, by turning the knob anti-clockwise.

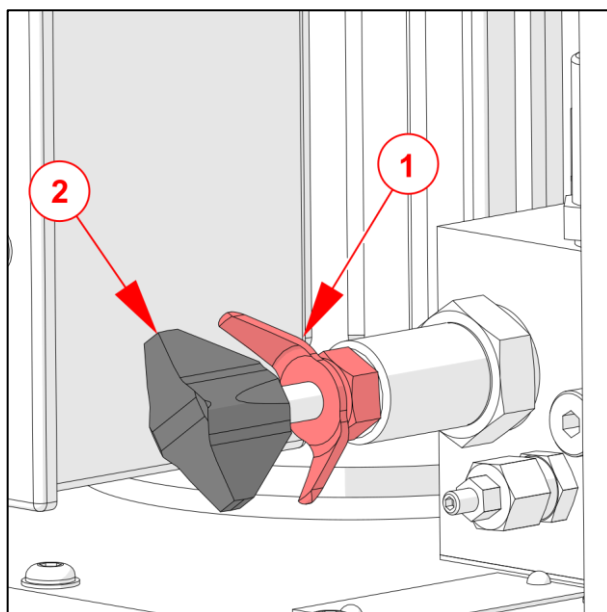

Figure 6.1: Setting the Pressure Relief Valve

- IMPORTANT:** The pressure must **ALWAYS** be adjusted from a lower pressure up to the target value, **NEVER** down from a higher pressure to the target pressure.
6. Re-press the advance button on the pendant and slowly increase the pressure until the desired pressure is achieved.
  7. While holding the pump at the desired pressure, tighten the wing nut [1] against the valve body. This will lock in the pump pressure at the correct level for the required torque tool output.
  8. Release the advance button and allow the tool to retract fully.
  9. Cycle the pump one more time to confirm the correct pressure and ensure nothing changed while fastening the wing nut.

## 6.3 Pendant Control Buttons (figure 6.2)

### ADVANCE

Once started the pump is started, pressing, and holding the 'Advance' button will set the pump to advance mode i.e. the wrench will advance. The pump will remain in this mode until the button is released. Once released the pump will return to retract mode and the wrench will retract.

### STOP/EMERGENCY STOP

The 'Stop/Emergency Stop' button, (11) on the control pendant (17) is pressed to stop the pump motor, either after use, or in the case of an emergency.

**⚠ CAUTION!** Pressing a 'Stop' button does not remove power from the electrical control box. The pump must be turned off and disconnected from the power source to remove power from the electrical control box.

Once pressed, the motor is locked in the off position and will not turn on until the button has been released. To release the button: Twist the button in the direction of the arrow until it pops up and releases.

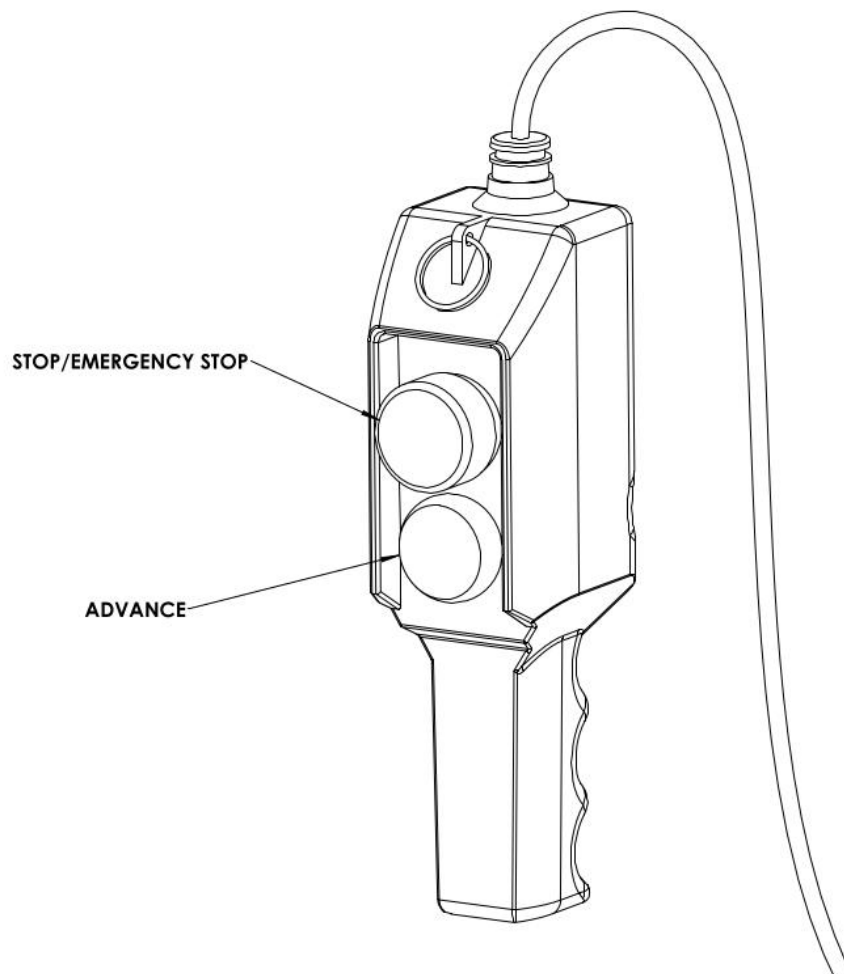

Figure 6.2: Hand Pendant Controls

## 6.4. Pump Operation

All operating functions of the pump are performed via the 2 buttons on the control pendant (17).

### **WARNING!**



Hi-force recommends that operation of the pump/wrench combination be a minimum 2-person job, one to operate the pump and one to operate the wrench. An additional operator will be required for each addition wrench connected to the pump.

To reduce the likelihood of a finger/hand trapping accident, at least one of the operators **MUST** be trained in the safe usage of the equipment and a clear system of communication **MUST** be established.

To ensure the safety of the torque tool operator/s, the pump **MUST ONLY** be operated once all torque wrench/tool operators have indicated it is safe to do so.

1. Prepare the pump for operation as per section 6.1.
2. Set the required pressure (torque) as per section 6.2.
3. Press the 'Motor Start' (19) button once on the 'Electrical Control Box' (10) to start the pump.
4. Press and hold the 'Advance' button to advance the tool. (See torque wrench operating instructions for more details about the wrench operation)
5. When the wrench stops advancing, release the 'Advance' button. The tool will automatically retract ready for the next operation.
6. Turn the pump off by pressing the 'Motor Stop' (19) button on the 'Electrical Control Box' (10).
7. **Good Practice:** Set the relief valve (12) to the fully open position (wound anti-clockwise) after use.
8. Disconnect from the power supply.

## 7.0 Maintenance and Storage

Carry out basic maintenance on a regular basis to keep the pump operating in a trouble-free manner. Maintenance intervals are determined by the frequency of use and the operating conditions on site.

- Keep the unit clean.
- The oil level in the reservoir **should not** be allowed to drop below the minimum gauge level during operation.

**ALWAYS** check the oil level with the tool/s in the fully advanced position to ensure an adequate amount of oil is available. Keep the oil reservoir topped-up with high grade **ISO46** hydraulic oil as per section 5.2.

**⚠ CAUTION!** If the oil level does fall below the minimum mark on the oil level indicator, air could be drawn into the pump causing erratic operation and possible damage. To top up hydraulic oil, See *Section 5.2*.

Oil should be replaced after approximately 500 working hours, or more frequently in dusty conditions. To replace the oil, disconnect from the power supply, remove the oil drain plug (16) on the bottom of the reservoir and drain the used oil into a suitable container. Replace the drain plug (16) and refill with high grade ISO46 hydraulic oil as per section 5.2.

**IMPORTANT:** **ALWAYS** dispose of used hydraulic oil in a responsible manner, in accordance with local regulations.

- After use, always retract the tool/s fully and disconnect the hoses. Fit dust caps to the couplings, every time disconnections are made.
- Routinely perform a visual inspection of the pump and electric cables for signs of damage. Any electrical cables showing signs of damage **MUST** be replaced by a Hi-Force authorised repair centre, or by a competent electrician.
- Store upright in clean and dry conditions.
- Pressure gauges should be calibrated at least once every 12 months.

## 8.0 Specifications

Refer to the nameplate on the pump for model identification.

TPE-AM   Torque Wrench Pumps – Electric Driven (Analogue)						
Model Number	Power Supply	Pressure Gauge	Gauge Reading	Oil Capacity (litres)	Max Oil Temp. (°C)	Weight (incl. oil) (kg)
TPE15AM	110V-1Ph 50Hz	Analogue	bar/psi	7	80°	39
TPE16AM	120V-1Ph 60Hz	Analogue	bar/psi	7	80°	39
TPE25AM	230V-1Ph 50Hz	Analogue	bar/psi	7	80°	39
TPE26AM	230V-1Ph 60Hz	Analogue	bar/psi	7	80°	39

The TPE-AM Pump Units use a 3-stage pump with the following pressure ranges and flow rates.

Pump Stage	Pressure Range (bar)	Flow Rate (l/min)	
		50Hz Motors	60 Hz Motors
1	0 - 65	6.5	7.8
2	65 - 325	1.5	1.8
3	325 - 700	0.75	0.9

### Sound Pressure Levels

An average A-Weighted sound pressure level of 88dB was measured for undefined workspaces, as per EU Directive 2006/42/EC Section 1.7.4.2 (u).

### Oil Temperature Control

TPE-AM pumps are fitted with a heat exchanger (3). Oil is circulated through the heat exchanger to restrict temperature rise. The heat exchanger cooling fan (15) will run constantly whilst the pump is plugged into the main electrical supply.

## **8.1 Oil Specification**

Hi-Force tools use 2 grades of oil, dependant on the tool. The tools are designed to operate at temperatures of -20 to 80 degrees C. Details of the oil used in this product can be found in Section 6.2.

ISO Hydraulic oil grade	Temperature range Degrees Celsius	
	From:	To:
ISO15	-23	44
ISO46	-2	73

## **9.0 System Components/Accessories**

*(Refer to the Hi-Force website or latest Hi-Force catalogue, for further details)*

- HTWH Series High-Pressure Hydraulic Hoses (Up to 100m).
- HTWR1 Torque Wrench Hose Reel
- High-Pressure Quick-Release Male and Female Half Couplers.
- Additional Torque Coupler Sets (*See section 5.4*)

## 10.0 Pressure Conversion Table

bar	psi	kgf/cm <sup>2</sup>		bar	psi	kgf/cm <sup>2</sup>
10	145	10.2		360	5221	367.1
20	290	20.4		370	5366	377.3
30	435	30.6		380	5511	387.5
40	580	40.8		390	5656	397.7
50	725	51.0		400	5802	407.9
60	870	61.2		410	5947	418.1
70	1015	71.4		420	6092	428.3
80	1160	81.6		430	6237	438.5
90	1305	91.8		440	6382	448.7
100	1450	102.0		450	6527	458.9
110	1595	112.2		460	6672	469.1
120	1740	122.4		470	6817	479.3
130	1885	132.6		480	6962	489.5
140	2031	142.8		490	7107	499.7
150	2176	153.0		500	7252	509.9
160	2321	163.2		510	7397	520.1
170	2466	173.4		520	7542	530.3
180	2611	183.5		530	7687	540.5
190	2756	193.7		540	7832	550.6
200	2901	203.9		550	7977	560.8
210	3046	214.1		560	8122	571.0
220	3191	224.3		570	8267	581.2
230	3336	234.5		580	8412	591.4
240	3481	244.7		590	8557	601.6
250	3626	254.9		600	8702	611.8
260	3771	265.1		610	8847	622.0
270	3916	275.3		620	8992	632.2
280	4061	285.5		630	9137	642.4
290	4206	295.7		640	9282	652.6
300	4351	305.9		650	9427	662.8
310	4496	316.1		660	9573	673.0
320	4641	326.3		670	9718	683.2
330	4786	336.5		680	9863	693.4
340	4931	346.7		690	10008	703.6
350	5076	356.9		700	10153	713.8

## 11.0 Troubleshooting

Hi-Force TPE-AM Torque Wrench Pumps should be serviced and repaired only by authorised Hi-Force repair centres. The following table gives possible causes and solutions for common problems.

TROUBLESHOOTING GUIDE		
Problem	Possible Cause	Solution
1. Pump will not start.	a. Not connected to the power supply.	Connect to the power supply.
	b. Damaged power cord.	Repair or replace the power cord.
	c. Faulty control pendant.	Contact your local Hi-Force office / distributor.
	d. "Emergency Stop" button pressed.	Twist the "STOP" Button clockwise to ensure it is released.
	e. Motor is damaged, seized or worn.	Contact your local Hi-Force office / distributor.
	f. Electrical Fault	Contact your local Hi-Force office / distributor.
2. Motor stalls or struggles to create pressure.	a. Low supply voltage.	i. Use heavier gauge extension cord. ii. Turn off excess electrical loads.
3. Pump struggles to build pressure or maintain pressure under load.	a. Oil level too low	Check unit for visible leaks as per 5.8. Add oil as per section 5.2.
	b. External oil leak in the system.	Contact your local Hi-Force office / distributor.
	c. Adjustable relief valve incorrectly set.	Adjust relief valve pressure as per section 6.2.
4. Pump running hot.	a. Low oil level.	Add oil as per section 5.2.
	b. High-Pressure leakage at pump.	Contact your local Hi-Force office / distributor.
5. Motor stops working after prolonged use.	a. Oil overheated.	Allow time for oil to cool. See section 8 for details.
6. Tool will not advance.	a. Pump malfunction.	Contact your local Hi-Force office / distributor.
	b. Oil level too low.	Add oil as per section 5.2.
	c. Faulty control pendant.	Contact your local Hi-Force office / distributor.
7. Tool advances automatically, without a pendant button being pressed.	a. Tool Incorrectly connected.	Swap Hose connections at the tool.
8. Pump will only reach 80-90 bar in advance mode, but higher in retract mode.	a. Tool Incorrectly connected.	Swap Hose connections at the tool.

### TROUBLESHOOTING GUIDE (continued...)

Problem	Possible Cause	Solution
---------	----------------	----------



9. Pump builds to full pressure, but tool does not advance/operate.	a. Advance or Return flow line to tool restricted or blocked.	Check couplers for full engagement.
	b. Required torque exceeds tool capacity.	Make sure the tool is correctly rated for the application.
10. Erratic tool movement.	a. Leakage from pump or valve internal components.	Contact your local Hi-Force office / distributor.
	b. Internal leak, due to damaged/worn seals or valves.	Contact your local Hi-Force office / distributor.
	c. Oil level too low.	Check unit for visible leaks. Add oil as per section 5.2.
	d. Air in the hydraulic system.	Bleed air from the system. (See section 5.7)
	e. Tool piston binding.	Contact your local Hi-Force office / distributor.
11. Tool stalls under load or before maximum torque is reached.	a. Control Valve damaged.	Contact your local Hi-Force office / distributor.
	b. Seal damage/wear or internal damage.	Contact your local Hi-Force office / distributor.
12. Noisy Operation	a. Air trapped in the hydraulic system.	Bleed air from the system. (See section 5.7)
	b. Air leaking into the hydraulic system.	Visually inspect all areas where air might leak into the hydraulic system.
	c. Oil level too low.	Check unit for visible leaks. Add oil as per section 5.2.

### Manual Pressure Dump

Always stop the pump by pressing the “Motor Stop” button (19) before attempting to connect or disconnect a hose/s. Attempting to disconnect hoses while the pump is running is dangerous and can result in leakage or injury.

When the pump is stopped, trapped oil pressure can be released by pressing the manual override button (4) located on top of the solenoid valve. This will make it easier to disconnect the hoses.

**Head Office:**

Hi-Force Limited

Prospect Way, Daventry

Northamptonshire NN11 8PL

United Kingdom

Tel: + 44 1327 301000 | Fax: + 44 1327 706555

[www.hi-force.com](http://www.hi-force.com)

**Regional Offices:**

For information on our offices worldwide, scan the below QR code.

