

This 'Original instructions' document assumes that the operator carrying out any operation with this product is trained and competent to do so. This manual does not attempt to cover all details or variations in the equipment. Nor does this manual claim to provide for every possible contingency met in connection with the installation, operation, or maintenance thereof. Should further information be desired, or should a particular problem arise which is not covered in sufficient detail, the matter should be referred to Hi-Force.

## OPERATING INSTRUCTION MANUAL

### TWS-N SERIES | HYDRAULIC TORQUE WRENCHES - SQUARE DRIVE

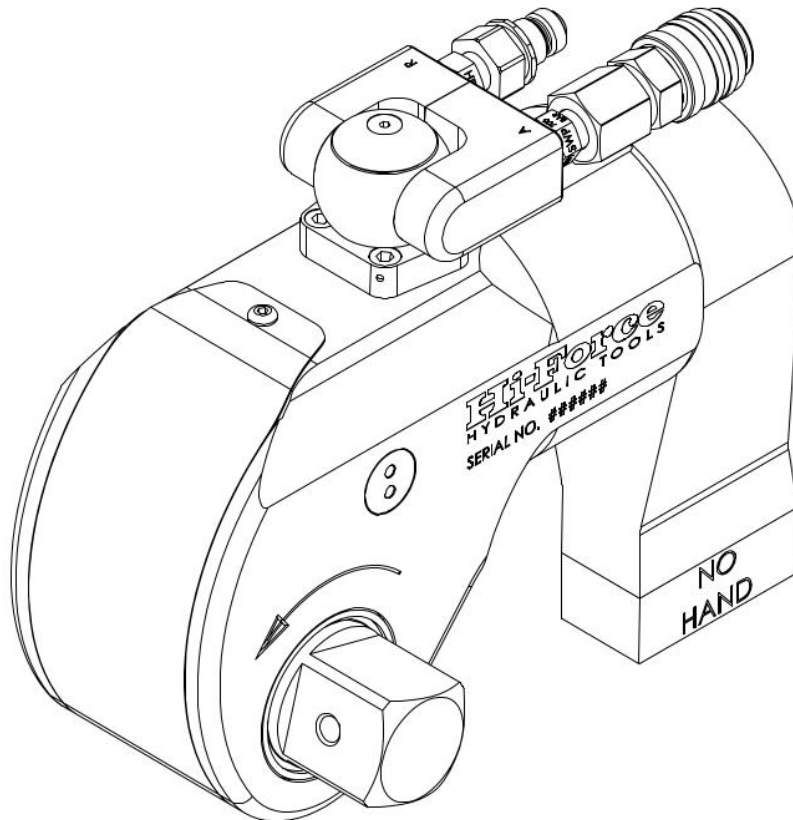

Hi-Force TWS-N series of lightweight aluminium Square Drive Hydraulic Torque Wrenches are designed to handle the toughest bolting jobs quickly and accurately. All models provide a torque accuracy of  $\pm 3\%$ . The reaction arm allows the user to easily position the tool and if necessary, react off the tool body in confined situations. TWS-N Torque wrenches are available in torque capacities up to 36992 N·m at a maximum working pressure of 700 bar (10,000 psi). This manual applies to the Hi-Force TWS-N series Hydraulic Torque Wrenches Only. It contains the latest product information available at the time of publication and approval. Hi-Force reserves the right to make changes to this document at any time without notice.

## Table of Contents

1.0 Inspection upon Receipt ..... 3

2.0 Safety Precautions..... 3

3.0 Declaration of Incorporation/Conformity ..... 6

4.0 Component Identification..... 7

5.0 Installation/Setup ..... 8

6.0 Operation ..... 14

7.0 Maintenance and Storage..... 16

8.0 Specifications..... 17

9.0 System Components/Accessories ..... 18

10.0 TWS-N Torque Conversion Charts ..... 19

11.0 Troubleshooting..... 20

TWS MODEL	SERIAL No.
TWS17N	FROM #####
TWS45N	FROM EB7667
TWS100N	FROM #####
TWS150N	FROM EB4776
TWS370N	FROM EB7917

**NOTE:** Images contained within this document are for illustrative purposes **ONLY**.

## 1.0 Inspection upon Receipt

Upon receipt of the product, visually inspect the item for any evidence of shipping damage. Please note: the warranty does not cover shipping damage. Notify the courier immediately if shipping damage is found and refrain from putting the product into service. The carrier is responsible for repair and replacement costs resulting from damage that occurred in transit.

## 2.0 Safety Precautions

### 2.1 Introduction



Read and follow all the instructions and safety warnings carefully before handling, installation or use of any hydraulic equipment. Failure to do so could lead to equipment damage, equipment failure, personal injury or even death. Hi-Force will not be held responsible for any damage to the equipment, injury or death resulting from the unsafe use of, lack of maintenance to, or incorrect operation of the product. If in doubt on the correct use of any Hi-Force equipment, contact your nearest Hi-Force office or distributor. Only qualified personnel should be allowed to operate hydraulic equipment. If an operator has not been trained on high-pressure hydraulic equipment and its safe usage, consult your local Hi-Force sales office or distributor who can offer training courses for operators.



### **CAUTION!**

Failure to observe and obey the following safety precautions could result in property damage, equipment damage or minor/moderate personal injury;

### 2.2 Work Area Safety

- Keep work areas clean and well lit. Cluttered spaces and inadequate lighting can result in unnecessary accidents.
- Keep unauthorised persons at a safe distance from the task site.
- **NEVER** use the tools in the presence of inflammable liquids, gases or material.
- **DO NOT** use the tools in potentially explosive atmospheres (ATEX) this tool is **NOT** ATEX approved.

### 2.3 General Hydraulic System Safety Precautions



### **WARNING!**

Failure to observe and obey the following safety precautions could result in property damage, significant personal injury or death;



- When operating any hydraulic equipment, all operators should ensure that all necessary personal protective equipment (PPE) is worn, as specified by their employer. Steel toe-cap safety shoes, safety glasses/visor, ear protection and protective gloves should be worn at all times. All relevant risk assessments should be completed before the use of the equipment.
- Keep hydraulic equipment away from open flames and direct heat.

- **NEVER** handle a pressurised hydraulic hose. Hydraulic oil escaping under pressure from a ruptured hose can penetrate the skin and lead to a significant medical emergency, and in some cases, death. Should this incident occur, seek out medical attention immediately.
- Inspect hoses regularly for damage and wear.
- Seek medical attention immediately if a hydraulic injection injury (no matter how minor) occurs.
- The system operating pressure **MUST NOT** exceed the pressure rating of the lowest-rated component in the system. It is good practice to use a pressure gauge to monitor the entire system.
- Only use hydraulic tools/cylinders in a complete and tested, coupled system. **NEVER** attempt to use a tool/cylinder that is not correctly coupled to its operational pump. **NEVER** pressurise an uncoupled coupler/s.
- **NEVER** attempt to disconnect a hose from a hydraulic system until the systems pressure has been completely released. Doing so can result in that pressure becoming trapped within the system and relieving trapped pressure can be dangerous.
- **NEVER** try to relieve trapped hydraulic pressure in the system by loosening or attempting to remove the coupler. Trapped hydraulic pressure can cause a loosened coupler to dislodge unexpectedly with great force. This action could result in serious personal injury or death, as the coupler could become a projectile and hit operatives in the working area.
- **NEVER** attempt to connect or disconnect, hydraulic equipment while the system is under pressure.
- Loosening a coupler under pressure can result in the escape of hydraulic oil at high pressure, which can penetrate the skin and cause significant injury or death.
- **NEVER** use a hammer and punch to unseat a coupler check valve that is under pressure. Doing so could result in the sudden, uncontrolled release of hydraulic oil at high pressure, which could cause significant injury or death.
- Immediately replace any worn or damaged parts using genuine Hi-Force parts only.
- **DO NOT** remove any labels from the product. Replace any damaged or unreadable label immediately.
- **DO NOT** use any hydraulic equipment if you are under the influence of alcohol, drugs or medication. Lack of attention whilst operating high-pressure hydraulic tools can result in personal injury or death.
- **NEVER** over-stroke a cylinder that is not fitted with a piston stop ring. Equipment failure and injury can occur. For cylinder safety guidelines and operation refer to the cylinder operating instructions.



## **CAUTION!**

**Failure to observe and obey the following safety precautions could result in property damage, equipment damage or minor/moderate personal injury;**

- **NEVER** lift or carry any hydraulic components by the hose or hoses connected to them.

- Avoid damaging hydraulic hose. **ALWAYS** route hoses to ensure that they are free from sharp bends and kinks. Using a bent or kinked hose will result in severe back-pressure, which can lead to hose failure.
- **ALWAYS** operate the system under no-load conditions before the actual operation, to ensure there is no air trapped in the hydraulic circuit.
- **NEVER** use a coupler/s to lift, carry or position a tool.
- Ensure that the lifting device/s are placed entirely under the load and that lifting is parallel.
- Servicing of hydraulic equipment must only be undertaken by a qualified technician.

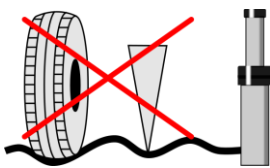

- **DO NOT** drop or place heavy objects on a hydraulic hose, as this may cause internal damage, which could result in rupture of the pressurised hose. A ruptured hose could cause significant damage to components and possible severe injury to personal operating nearby.

- The manufacturer rated load capacity and stroke length for cylinders represent the maximum safe limits. Good practice use 80% of the rated figures, as the maximum values for load capacity and stroke length.
- Select cylinders with sufficient over-capacity. See the guidance above.

For multi-cylinder lifting operations, 50% of the total number of cylinders used should be able to withstand the full weight of the load being lifted/lowered. I.e. The system capacity should be at least twice that of the load being lifted/lowered.

- **DO NOT** let familiarity gained with any hydraulic tools allow you to become complacent. Complacency with any tooling can result in a lack of discipline toward working guidelines and safety principles.
- Avoid loose clothing and jewellery that could get caught in moving parts, tie back long hair.

## 2.4 Hydraulic Torque Wrench Specific Safety Precautions



**WARNING!** Failure to observe and obey the following safety precautions could result in property damage, serious personal injury or death;

- **NEVER** exceed the maximum rated pressure of any hydraulic equipment. Hi-Force manufactures its TWS-N torque wrenches to operate at a maximum working pressure of 700 bar (10,000 psi). **DO NOT** connect a pump with a higher pressure capacity rating to any Hi-Force tool of this model series.
- **NEVER** attempt to connect or disconnect, hydraulic equipment while the system is under pressure.
- **DO NOT** weld any items to the torque wrench or modify it in any way from its delivered condition. Your warranty may be invalidated, and it could lead to serious personal injury.
- **ALWAYS** ensure there is clear communication between the pump operator and the tool operator. **DO NOT** operate the pump unless the tool operator indicates it is safe to do so.

Take extra care when multiple tools are being operated by a single pump. Make sure all tool operators have given the go-ahead before operating the pump.

- **NEVER** operate the torque wrench without both hydraulic hoses connected to it.
- This tool will exert very large reaction forces. Use proper mechanical support and correct reaction arm positioning to control these forces. **DO NOT** position the reaction arm so that it tilts the tool off the axis of the bolt and **NEVER** use the uni-swivel coupling as a reaction point.
- **NEVER** attempt to use your hands or any other body parts as a reaction point for the tool during operation.
- This tool is **NOT ATEX RATED**. I.e. **NOT** suitable for work which takes place in explosive environments.
- This tool is **NOT** insulated against electric shock. When using this tool with a pump that has an electrical power source or circuits, follow the pump instructions for proper grounding.



## **CAUTION!**

**Failure to observe and obey the following safety precautions could result in property damage, equipment damage or minor/moderate personal injury;**

- **ALWAYS** wear appropriate personal protective equipment (PPE) when carrying out maintenance on this tool.
- When connecting hoses that have not been pre-filled with hydraulic oil, make certain the pump reservoir is not drained of oil during start-up.
- **ONLY** use impact sockets and accessories. **DO NOT** use hand (chrome) sockets or accessories.
- **ONLY** use Hi-Force recommended accessories.
- **ONLY** use sockets and accessories that correctly fit the nut/bolt and function without tilting the tool off the axis of the bolt.
- **DO NOT** interchange the male and female swivel inlets on the tool or the connections on one end of the hose. Reversing the inlets will reverse the power stroke cycle and may damage the tool.
- To protect your warranty, only use the hydraulic oil grade specified in Section 8.1.

### **3.0 Declaration of Incorporation/Conformity**

**Hi-Force declares that this product has been tested and complies with the standards set out in 2006/42/EC - The Machinery Directive. The Declaration of Incorporation/Conformity is included as Annex A to this instruction document and is supplied with all shipments of this product.**

## 4.0 Component Identification

1	Drive Unit	5	Male 'Retract' Coupler (90 bar)
2	Square Drive (Reversible)	6	Female 'Advance' Coupler (700 bar)
3	Shroud	7	Reaction Arm (Multi-Position)
4	360° X 180° Swivel Assembly	8	Release Button Assembly

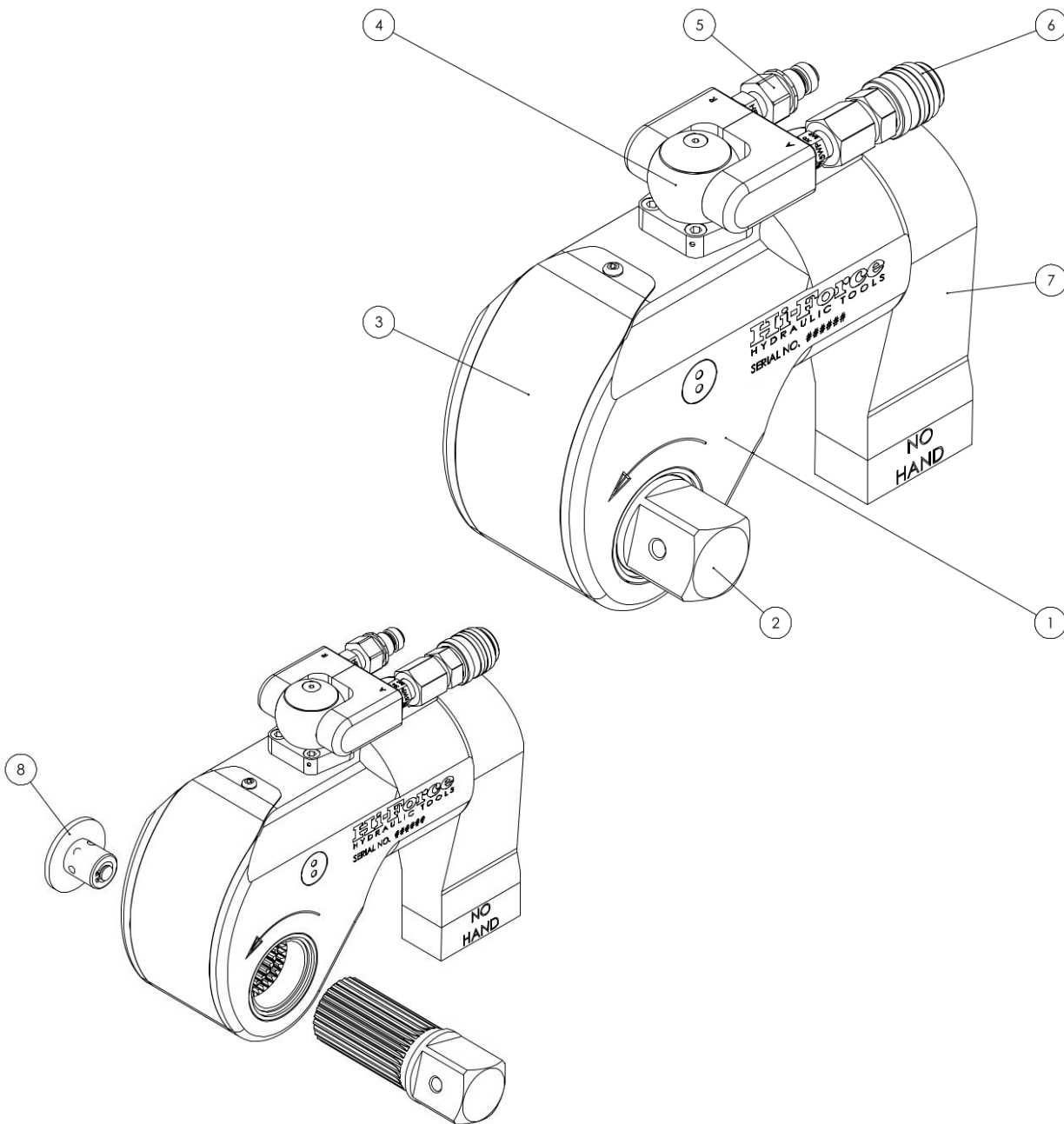

Figure 4.1: Component Identification



## 5.0 Installation/Setup

**IMPORTANT:** Images used through-out this manual are for illustrative purposes **ONLY**. Images may display a different system configuration and different tools or accessories to those being used. Additionally, some details may have been removed for clarity purposes.

### 5.1 Before Each Use

- Check the exterior of the tool for signs of mechanical damage and/or oil leaks. If either is present, **DO NOT** use the equipment until it has been serviced and returned to its proper operating condition.

### 5.2 Hydraulic Connections

 **WARNING!** TWS-N torque wrenches are double-acting torque tools (powered in both the advance and retract directions) and **MUST** be connected to the pump via both, the advance and retract couplers. **DO NOT** pressurise the pump/system if there are any disconnected couplers in the system.

- **ALWAYS** use Hi-Force HTWH hoses to make connections.
- Hi-Force TWS-N torque wrenches are fitted with dual flat-face quick-connect couplers.
- Make sure both coupler halves are clean before connecting.

 **WARNING!** If you are **NOT** using a Hi-Force Torque Wrench pump, or if the pump or hoses have been modified, make sure that the wrench is connected correctly so that the female high-pressure advance coupler (2) is connected to the advance port on the pump. Failure to do so may result in leakage, tool damage or personal injury.



## 5.2.1 Connections (See figure 5.1)

Connections between couplers are made by simply [1] pressing the male coupler into the female coupler until [2] the locking collar springs forward and locks the couplers together.

### **⚠ WARNING!**

Make certain the spring-loaded retaining rings are fully engaged to prevent the connectors from disengaging under pressure. A gentle tug on the hose should be enough to make sure the hose is correctly connected.

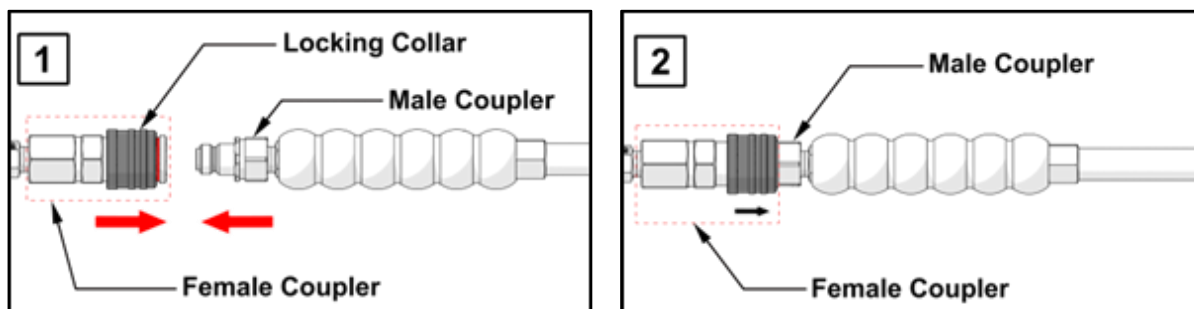

Figure 5.1: Hydraulic Connections

## 5.2.2 Disconnections (See figure 5.2)

### **⚠ WARNING!**

Always make sure the pump is switched off and pressure has been fully released before disconnections are made.

To disconnect couplers; [1-1] twist the locking collar on the female coupler in the direction of arrow and [1-2] pull back toward the female coupler body. [2] With the locking collar retracted, pull the male and female couplers apart. Fit dust caps after disconnections are made.

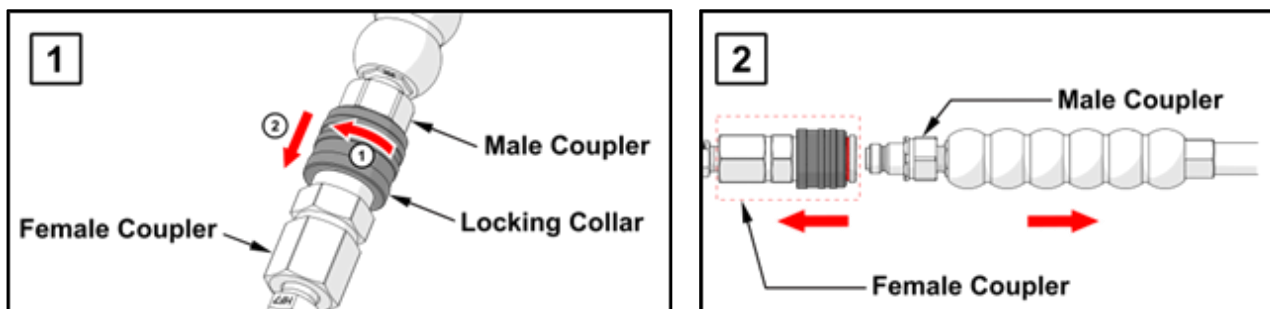

Figure 5.2: Hydraulic Disconnections

### 5.2.3. Connecting a Torque Wrench to the Pump

- Connect the female coupler on the red hose to the male advance coupler on the pump.
- Connect the male coupler on the black hose to the female retract coupler on the pump.

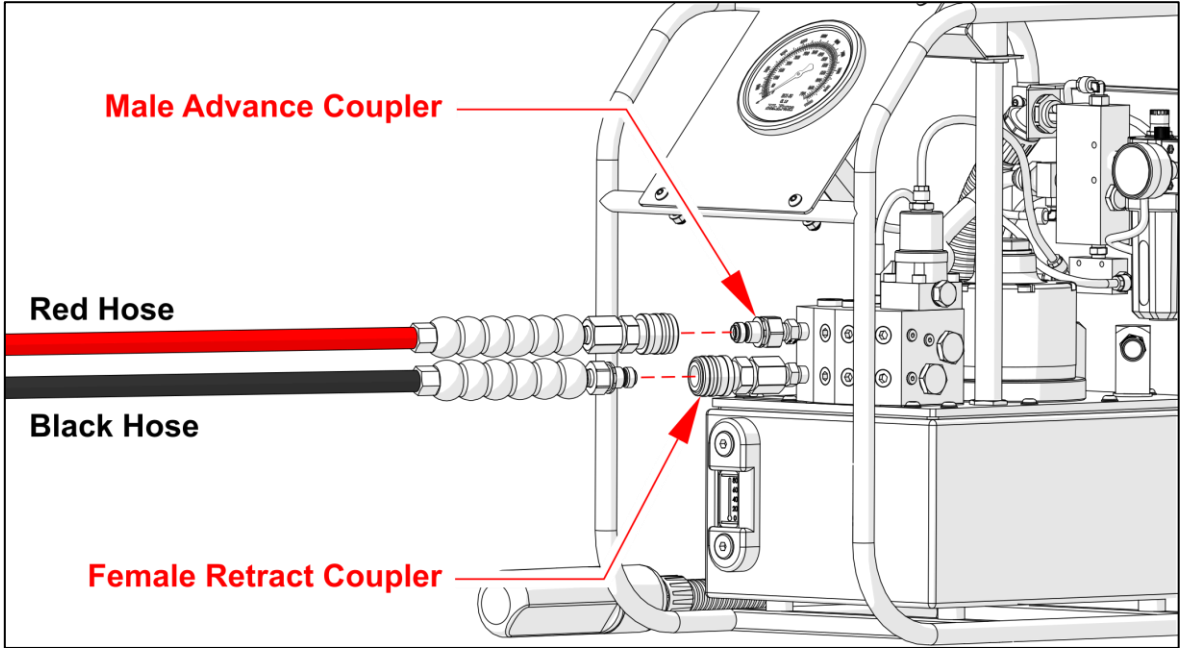

Figure 5.3: Connecting to the Pump

- Connect the free end of the red hose to the advance port on the torque wrench.
- Connect the free end of the black hose to the retract port on the torque wrench.

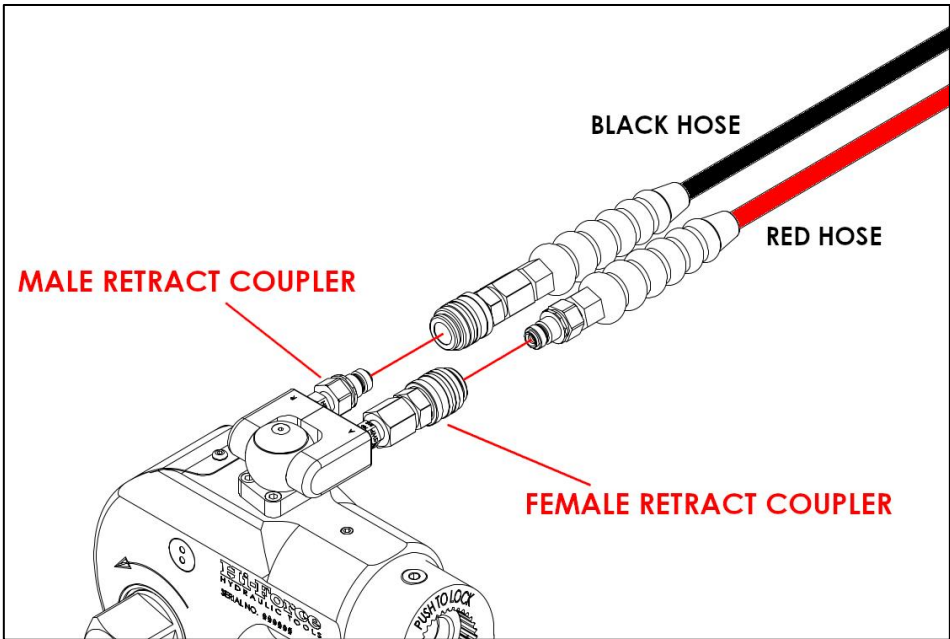

Figure 5.4: Connecting the Torque Wrench

### 5.3 Setting the Direction of Rotation of the Square Drive

The position of the Square Drive when looking toward the Shroud will determine if the tool is set to tighten or loosen the nut/bolt (See below).

Looking at the front of the tool, with the reaction arm pointed away from you;

- When the square drive extends to the **RIGHT**, the tool is set to **TIGHTEN** the nut/bolt.
- When the square drive extends to the **LEFT** the tool is set to **LOOSEN** the nut/bolt.

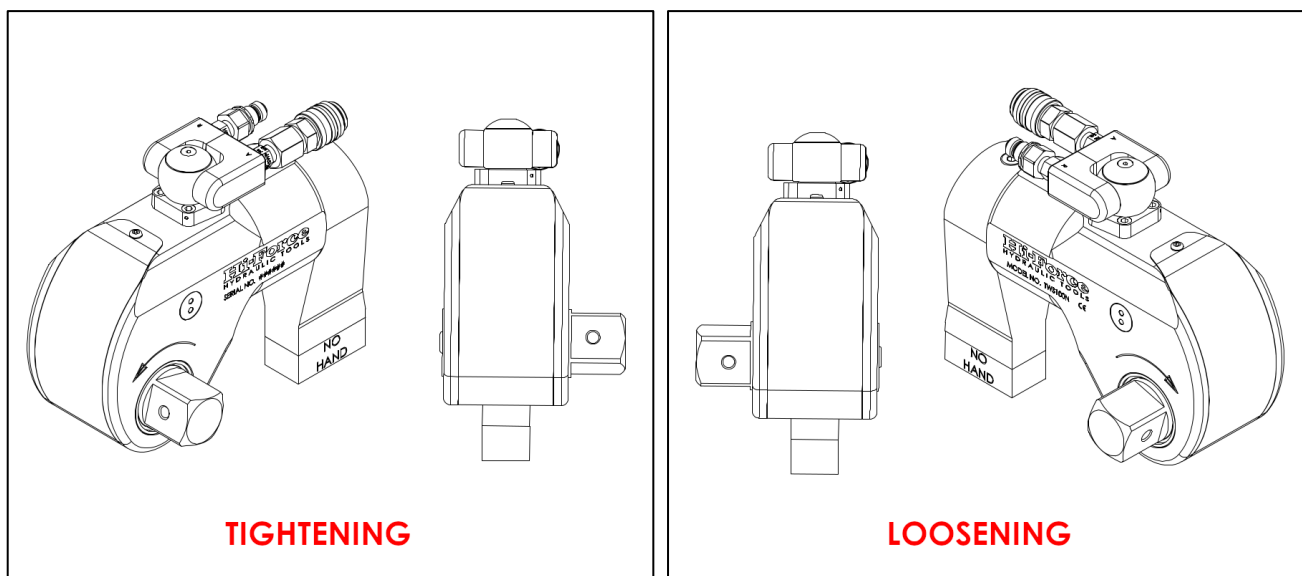

*Figure 5.5: Direction of Rotation of the Square Drive*

To change the direction of rotation, proceed as follows:

- Press in the push-button release on the release button assembly and at the same time pull the square drive out of the housing. (Refer to section 4.0)
- Release the push button on the release button assembly and allow the retaining plate to drop out of the tool body into your hand.
- Insert the square drive into the cavity on the opposite side of the tool body (where the release button assembly was previously)
- Secure the square drive by installing the release button assembly onto the end of the square drive.

### 5.4 Setting the Torque

After determining the required torque, use either the torque conversion chart engraved on the shroud or the torque conversion charts on page 19 of this manual to determine the pressure necessary to achieve the desired torque output.

Refer to the pumps operating instructions manual for a detailed procedure for setting the pumps output pressure to that determined above.

## 5.5 Reaction Surfaces

The function of the reaction arm/surface is to hold the tool in position against the forces generated to tighten or loosen bolts or nuts. Hydraulic wrenches generate tremendous torque (rotational) forces.

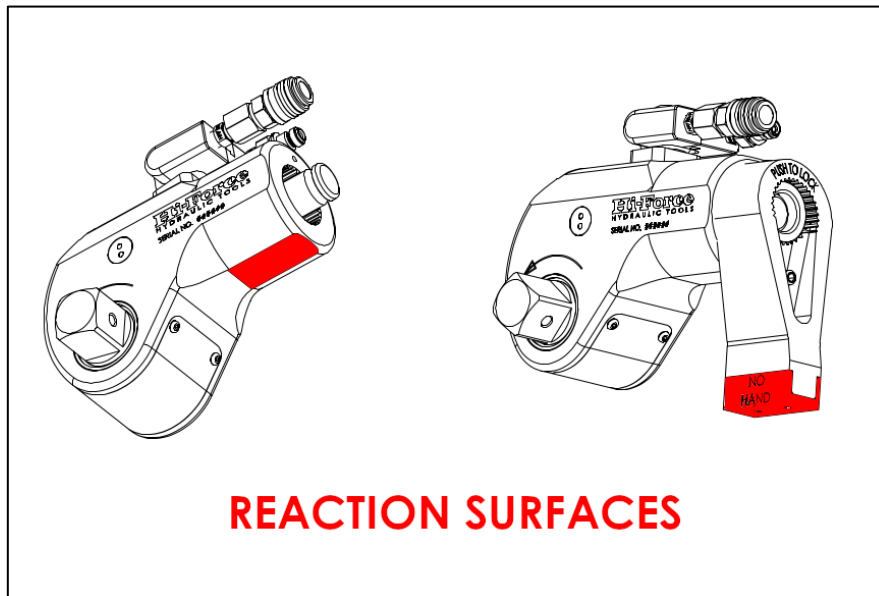

Figure 5.6: Reaction Surfaces

### 5.5.1 Setting the Reaction Arm

Make sure the reaction arm is positioned correctly. (See Figure 5.7)

The reaction arm can be positioned in numerous positions within a 360° circle. However, for the arm to be correctly positioned, it **MUST** be set within a 90° quadrant of that circle. That quadrant is the area located between the protruding square drive and the bottom of the housing away from the swivel inlets. It will always be toward the lower half of the housing and on one side of the housing when tightening and the other side when loosening.

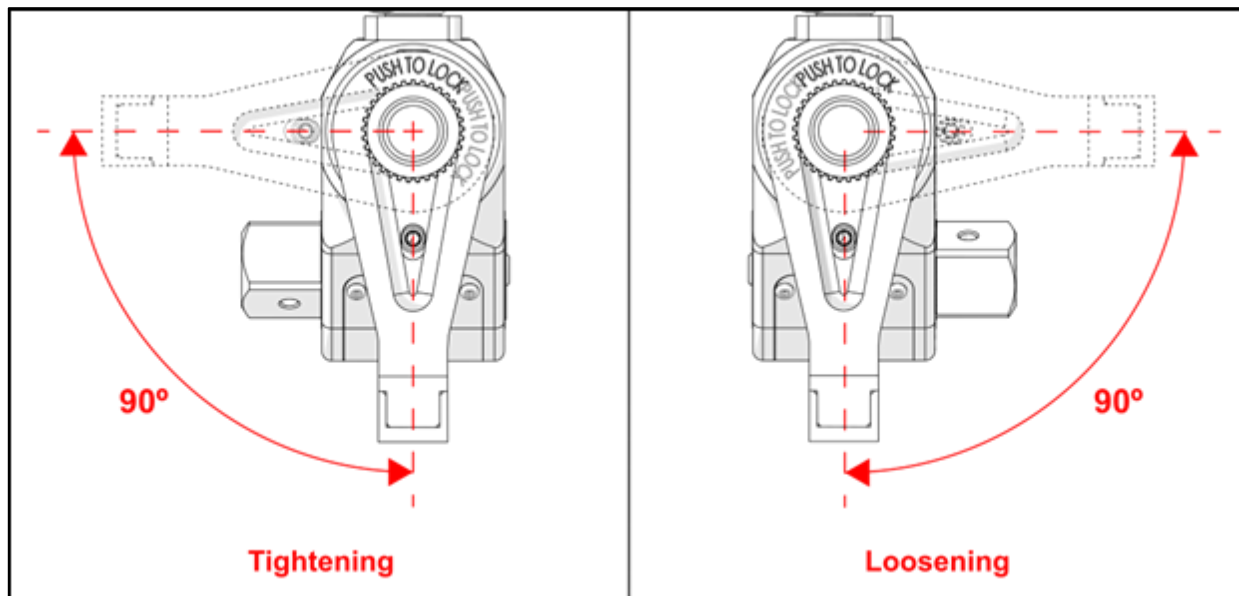

Figure 5.7: Correct Reaction Arm Quadrants

To remove the reaction arm, simply pull down on the release latch and pull the reaction arm away from the tool body.

To replace the reaction arm, orient it to the desired position and push onto the reaction arm location plug until it latches into place. A simple tug on the reaction arm will be enough to tell if it has attached correctly.

**NOTE:** Under certain conditions, it is possible for the reaction arm location plug to be pushed slightly into the body. This can happen as a result of the tool being dropped or hit against a solid object while the arm is not fitted. Once this has occurred the reaction arm may not latch into place correctly.

The problem is very simply cured and in many cases will rectify itself before the operator is even aware it has occurred. To return the plug to its correct position simply connect the tool to a pump and cycle the mechanism backwards and forwards a couple of times. In a lot of cases just switching the pump on will be enough. The reaction arm should then latch on correctly.

### **5.5.2 Extended Reaction Arm**

The extended reaction arm can only be positioned in one orientation i.e. the flat of the reaction surface at 90° to the side of the torque wrench body.

**NOTE:** The extended reaction arm is purchased separately as an accessory. For further information please contact your nearest Hi-Force office / distributor.

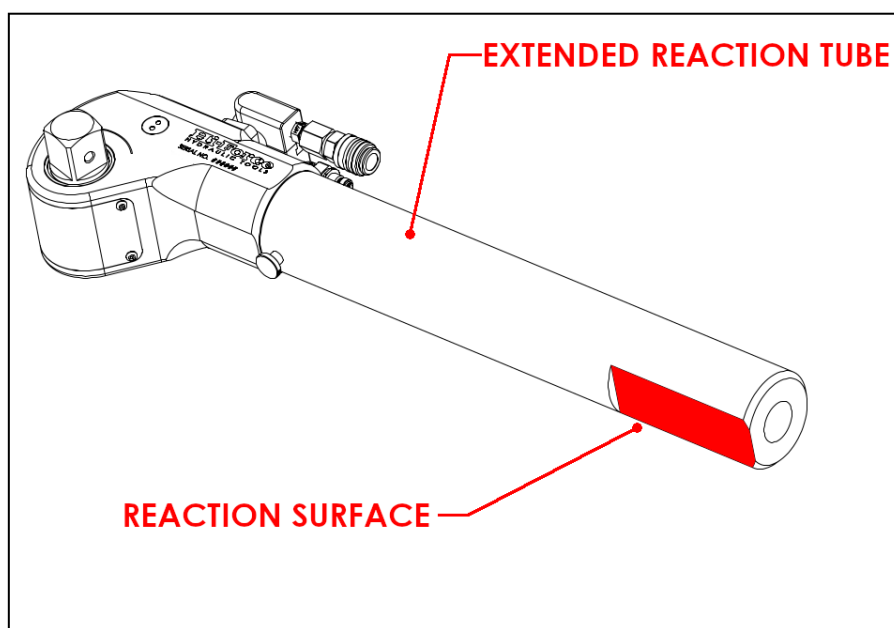

*Figure 5.8: Extended Reaction Arm Orientation & Reaction Surface*

### **5.6 Bleeding Trapped Air from the System**

Refer to the pumps operating instructions for the correct procedure.

## 6.0 Operation

Hi-Force TWS-N Torque Wrenches require a suitable double-acting Hydraulic Torque Wrench pump for operation. Make sure you read this manual in conjunction with the Torque Wrench Pumps operating instruction manual to ensure correct and safe operation of all hydraulic equipment in the system.

Before applying pressure to the system make sure you observe the following points

- You are aware of the correct operation of the Torque Wrench Pump.
- You are aware of the maximum working pressure of the Torque Wrench/s.
- You are aware of the maximum torque/tension the stud/bolt can withstand.
- You are aware of the required working pressure/s that must be applied to the Torque Wrench/s.
- You have read and fully understood the torquing sequence and procedure.
- You have performed the relevant risk assessment/s and have a method statement (safe system of work) for all operators to follow.

### 6.1 Operating the Wrench



#### **WARNING!**

Hi-force recommends that operation of the pump/wrench combination be a minimum 2 person job, one to operate the pump and one to operate the wrench. An additional operator will be required for each addition wrench connected to the pump.

To reduce the likelihood of a finger/hand trapping accident, at least one of the operators **MUST** be trained in the safe usage of the equipment and a clear system of communication **MUST** be established.

To ensure the safety of the torque tool operator/s, the pump **MUST ONLY** be operated once all torque wrench/tool operators have indicated it is safe to do so.

The position of the Square Drive relative to the Shroud determines whether the action will tighten or loosen the nut. The power stroke of the Piston Assembly will always turn the Square Drive toward the Shroud.

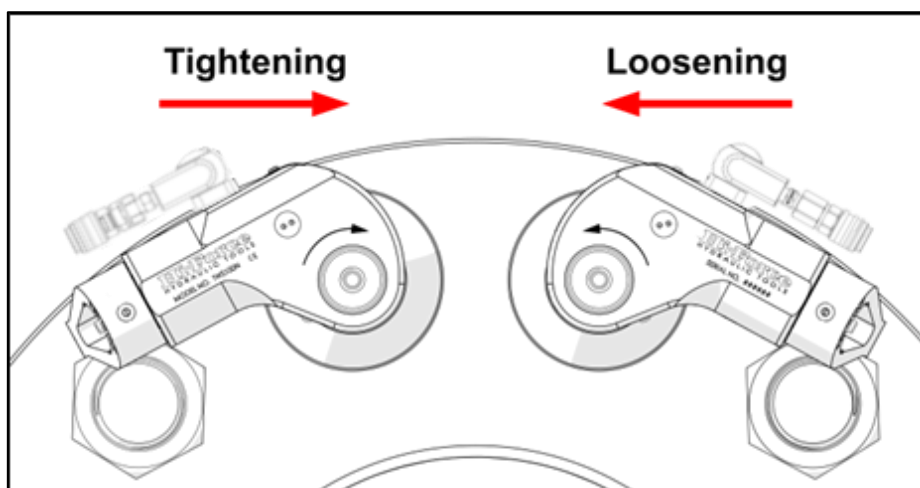

*Figure 6.1: Positioning the Torque Wrench*

1. Place the chosen socket on the squared drive shaft and insert the socket retainer ring and pin.
2. Place the socket on the nut/bolt to be tightened/loosened. (Make sure the square drive and socket are the correct size for the nut/bolt and that the socket fully engages it).
3. Position the reaction surface against an adjacent nut, flange or other solid, system component. (Make sure that there is clearance for the hoses and swivel coupling assembly).

**DO NOT** allow the tool to react against the hoses or swivel assembly coupling.

 **CAUTION!**

When the reacting directly of the tool body i.e. with the reaction arm removed.  
**DO NOT** react off the exposed end plug spigot.



**WARNING!**

When first placed, there will be a gap between the reaction surface and the contact point, creating a potential pinch point.

Make sure the wrench is held/supported in such a way that no body part is ever placed between the tool and the reaction surfaces.

4. After turning on the pump and pre-setting the pressure for the correct torque, signal the pump operator to depress the advance button on the control pendant and advance the piston assembly. (See pump manual)

When started, the reaction surface of the wrench or reaction arm will move against the contact point and the nut will begin to turn. Once the piston reaches the end of its stroke, the pressure will rise rapidly.

5. Retract the wrench fully.

On a pump with a '2 button' control pendant, press and hold the retract button to retract the piston. On a pump with a single button pendant (automatic retract), release the button to retract the tool. Under normal conditions, a series of audible clicks will be heard as the tool retracts.

6. Continue this cycling operation of advance and retract. As the nut tightens and the applied torque increases the nut rotation will slow and fewer audible clicks will be heard on retraction.
7. Continue to cycle the tool until it "stalls" (no further audible clicks will be heard on retraction) and the pre-set pressure/torque has been attained.
8. Once the nut stops rotating, cycle the tool on last time to achieve total torque.



## 7.0 Maintenance and Storage

Carry out basic maintenance on a regular basis to keep the torque wrench operating in a trouble-free manner. Maintenance intervals are determined by the frequency of use and the operating conditions on site.

- Keep the unit clean.
- After use, always retract the tool fully before disconnecting the attached hoses. Fit dust caps to the couplers, every time disconnections are made.
- Routinely perform a visual inspection of the tool for signs of damage.
- Store in clean and dry conditions.
- Apply lubrication as necessary.

### Lubrication

#### **Lubricant: Molybdenum Disulphide Grease**

Marine Grade Moly Lube is formulated not to wash out of the tool in areas where lubrication is critical.

Lubrication frequency is dependent on factors known only to the tool user.

Whenever lubrication is required, lubricate as follows:

1. Remove the Drive Plate, Ratchet, Segment Pawl and Drive Sleeves and wash the components in a suitable cleaning solution, in a well-ventilated area.
2. After drying the components, wipe a film of Moly Lube (Marine Grade) onto the wear surfaces of both Drive Sleeves and the ends of the Ratchet.
3. Spread a light film of Moly Lube (Marine Grade) onto the inner face and both sides of the Drive Plate.

**IMPORTANT: DO NOT** pack the teeth of the Segment Pawl or Ratchet with lube. Doing so can prevent the teeth from engaging properly.

## 8.0 Specifications

### 8.1 Oil Specifications

Hi-Force tools will use 1 of 2 grades of oil, dependant on the pump used. The tools are designed to operate at temperatures between -20°C and 80°C. Details of the oil used can be found in the chosen Hi-Force pump's operating manual, in the section: **FILLING OF PUMP WITH OIL.**

Hi-Force Model Number	ISO Hydraulic Oil Grade	Temperature Range: Degrees Celcius (°C)	
		From:	To:
HFO15	ISO15	-23	44
HFO46	ISO46	-2	73

### 8.1 TWS-N Specifications

Refer to the engraved detail on the torque wrench body for model identification.

TWS-N   Square Drive Hydraulic Torque Wrenches				
Model Number	Torque Capacity		Square Drive Size	Weight (kg)
	Nm at 700 bar	lbf.ft at 10,000psi		
TWS17N	1727	1254	¾"	1.9
TWS45N	4529	3289	1"	4.8
TWS100N	10064	7427	1½"	9.0
TWS150N	14974	10873	1½"	15.0
TWS370N	36992	26860	2½"	32.5

## **9.0 System Components/Accessories**

*(Refer to the Hi-Force website or latest Hi-Force catalogue, for further details)*

- HTWH Series High-Pressure Hydraulic Hoses (Up to 100m).
- HTWR1 Torque Wrench Hose Reel.
- High-Pressure Quick-Release Male and Female Half Couplers.
- Metric & Imperial Hexagon AF Size Heavy Duty Sockets.
- Metric & Imperial Allen Hex Drive Adaptors.
- Extended Reaction Arms.
- Removable Handle Kits.

## 10.0 TWS-N Torque Conversion Charts

PSI	PSI / lbf.ft					BAR / N·m					
	TWS17N	TWS45N	TWS100N	TWS150N	TWS370N	BAR	TWS17N	TWS45N	TWS100N	TWS150N	TWS370N
	(lbf.ft)	lbf.ft	(lbf.ft)	lbf.ft	lbf.ft		N·m	N·m	N·m	N·m	N·m
<b>1000</b>	125	329	731	1,087	2,686	<b>100</b>	247	647	1,438	2,139	5,285
<b>1500</b>	188	493	1,096	1,631	4,029	<b>150</b>	370	971	2,157	3,209	7,927
<b>2000</b>	251	658	1,462	2,175	5,372	<b>200</b>	493	1,294	2,875	4,178	10,569
<b>2500</b>	314	822	1,827	2,718	6,715	<b>250</b>	617	1,618	3,594	5,348	13,221
<b>3000</b>	376	987	2,192	3,262	8,058	<b>300</b>	740	1,941	4,313	6,417	15,854
<b>3500</b>	439	1,151	2,558	3,806	9,401	<b>350</b>	863	2,265	5,032	7,487	18,496
<b>4000</b>	502	1,316	2,923	4,349	10,744	<b>400</b>	987	2,588	5,751	8,556	21,138
<b>4500</b>	564	1,480	3,289	4,893	12,087	<b>450</b>	1,110	2,912	6,470	9,626	23,780
<b>5000</b>	627	1,645	3,654	5,437	13,430	<b>500</b>	1,234	3,235	7,189	10,696	26,423
<b>5500</b>	690	1,809	4,019	5,980	14,773	<b>550</b>	1,357	3,559	7,907	11,765	29,065
<b>6000</b>	752	1,973	4,385	6,524	16,116	<b>600</b>	1,480	3,882	8,626	12,835	31,707
<b>6500</b>	815	2,138	4,750	7,067	17,459	<b>650</b>	1,604	4,206	9,345	13,904	34,349
<b>7000</b>	878	2,302	5,116	7,611	18,802	<b>700</b>	1,727	4,529	10,064	14,974	36,992
<b>7500</b>	941	2,467	5,481	8,155	20,145						
<b>8000</b>	1,003	2,631	5,846	8,698	21,488						
<b>8500</b>	1,066	2,796	6,212	9,242	22,831						
<b>9000</b>	1,129	2,960	6,577	9,786	24,174						
<b>9500</b>	1,191	3,125	6,943	10,329	25,517						
<b>10,000</b>	1,254	3,289	7,308	10,873	26,860						

## 11.0 Troubleshooting

Hi-Force TWS-N Square Drive Torque Wrenches should be serviced and repaired only by authorised Hi-Force repair centres. The following table gives possible causes and solutions for common problems.

<b>TROUBLESHOOTING GUIDE</b>		
<b>Problem</b>	<b>Possible Cause</b>	<b>Solution</b>
1. Piston will not advance or retract.	a. Couplers not securely attached to the tool or pump.	Check the coupler connections and make sure they are connected correctly and fully engaged.
	b. Defective coupler.	Replace defective coupler.
	c. Faulty control pendant.	See pump manual or contact your local Hi-Force office / distributor.
	d. Pump malfunction.	See pump manual or contact your local Hi-Force office / distributor.
	e. Oil level too low.	See pump manual.
2. Tool will not retract.	a. Hose connections reversed.	Make sure the advance coupler on the pump is connected to the advance coupler on the tool and that the retract coupler on the pump is connected to the retract coupler on the tool.
	b. Retract hose not connected.	Connect the retract hose securely.
3. Tool will not build/hold pressure.	a. Piston seal and/or end plug seal leaking.	Replace defective seals.
	b. Defective coupler.	Replace defective coupler.
4. Square drive will not turn.	a. Lubricant or dirt build-up in the teeth of the ratchet and segment pawl.	Disassemble the ratchet and clean the grease or dirt out of the teeth.
	b. Worn or broken teeth on the ratchet and/or pawl segment.	Replace worn or damaged parts.
5. Tool advances automatically, without a pendant button being pressed.	a. Tool Incorrectly connected.	Swap Hose connections at the tool.
6. Pump will only reach 80-90 bar in advance mode, but higher in retract mode.	a. Tool Incorrectly connected.	Swap Hose connections at the tool.

**TROUBLESHOOTING GUIDE (continued...)**

Problem	Possible Cause	Solution
7. Erratic tool movement.	a. Leakage from pump or valve internal components.	See pump manual or contact your local Hi-Force office / distributor.
	b. Internal leak, due to damaged/worn seals or valves.	See pump manual or contact your local Hi-Force office / distributor.
	c. Oil level too low.	See pump manual.
	d. Air in the hydraulic system.	Bleed air from the system (See pump manual)
	e. Tool piston binding.	Contact your local Hi-Force office / distributor.
8. Tool stalls under load or before maximum torque is reached.	a. Control Valve damaged.	See pump manual.
	b. Seal damage/wear or internal damage.	See pump manual.
9. Noisy Operation	a. Air trapped in the hydraulic system.	Bleed air from the system (See pump manual)
	b. Oil level too low.	See pump manual.

**Head Office:**

Hi-Force Limited  
Prospect Way, Daventry  
Northamptonshire NN11 8PL  
United Kingdom  
Tel: + 44 1327 301000 | Fax: + 44 1327 706555  
[www.hi-force.com](http://www.hi-force.com)

**Regional Offices:**

For information on our offices worldwide, scan the below QR code

