

REVISION

1	4504
2	4753
3	5597
4	6308
5	6469
6	
7	
8	
9	
10	
11	
12	
13	
14	
15	
16	
17	
18	
19	
20	

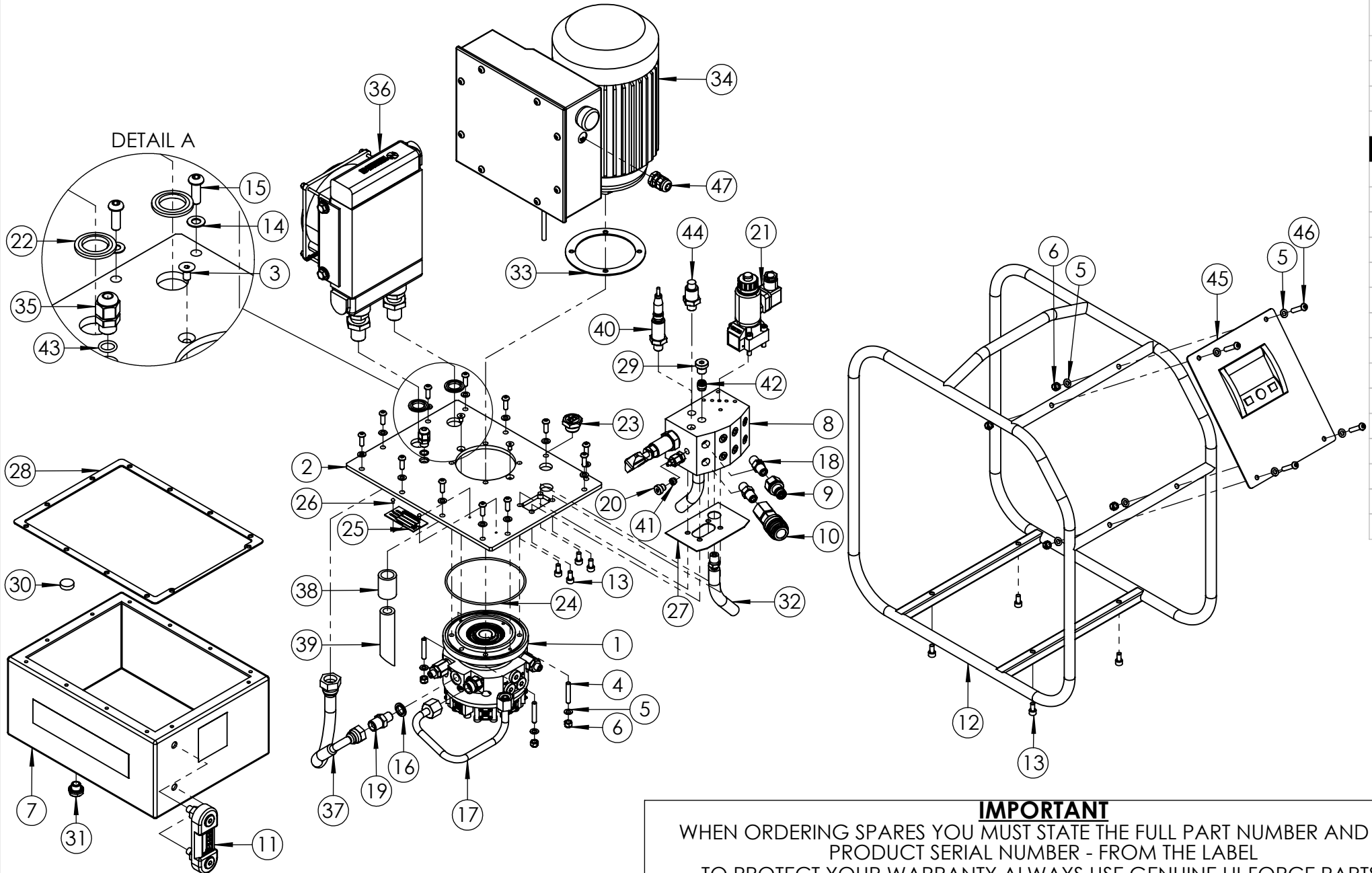

IMPORTANT
WHEN ORDERING SPARES YOU MUST STATE THE FULL PART NUMBER AND THE
PRODUCT SERIAL NUMBER - FROM THE LABEL
TO PROTECT YOUR WARRANTY ALWAYS USE GENUINE HI-FORCE PARTS.

ITEM NO.	PART NUMBER	DESCRIPTION	QTY.	SPARE PARTS	SERVICE PARTS
1	PMA019DT001	PUMP HEART	1		
2	TAC007BL003	TANK LID	1		
3	BLC005HF010	SOCKET CSK SCREW M5 x 10	2		
4	BLC006ST000	M6X35MM ENGINEERING STUD	4		
5	WAC006AF000	M6 ZINC WASHER	12		
6	NUC006JC000	M6 NYLOK NUT	8		
7	TAC007AL002	OIL RESERVOIR	1		
8	VFA006RN002	VALVE BLOCK	1		
9	CM4F	COUPLER	1		
10	CF4F	COUPLER	1		
11	TAC000FT006	LEVEL TEMP GAUGE	1		
12	TAC007CS004	ROLL FRAME	1		
13	BLC006JC012	M6 x 12 SOCKET CAP HEAD SCREW	8		
14	WAC006EB000	M6 WASHER	12		
15	BLC006JH018	M6 x 18 SOCKET BUTTON HEAD SCREW	12		
16	WAC007HD000	1/4" BSP SELF CENTERING BONDED WASHER	1	*	✓
17	HOC010PS002	PRE BENT TUBE ASSEMBLY	1		
18	HF7	1/4" NPT MALE ADAPTOR	2		
19	FPC010NB001	3/8" BSP CONE MALE - 1/4" BSP CONE MALE ADAPTOR	1		
20	FPC003PB001	BLANKING PLUG	1		
21	VFC000CD010	3/2 VALVE	1		
22	WAC012HD001	DOWTY WASHER	2	*	✓
23	BPC020VP001	FILLER PLUG (VENTED)	1		
24	SEC119RF001	O-RING I.D. 75.57MM, CS 5.33MM 70 SHORE (BS157)	1	*	✓
25	AAN000UP001	60 x 30 mm UNIVERSAL NAME PLATE	1	*	
26	FAS002HZ001	NO.4 x 3/16 HAMMER DRIVE SCREW	2		
27	SEC001KT005	VALVE GASKET	1	*	✓
28	SEC001KT008	TANK GASKET	1	*	✓
29	FPC006PB002	BLANKING PLUG	1		
30	DCSF00328	DOUBLE SIDED MAGNET	1		
31	BPC013EP001	DRAIN PLUG	1		

ITEM NO.	PART NUMBER	DESCRIPTION	QTY.	SPARE PARTS	SERVICE PARTS	REVISION
32	HOC006AB005	RETURN HOSE	1			1 4504
33	SEC002KT017	PUMP GASKET	1	*	✓	2 4753
34	EMTPE45A	MOTOR AND CONTROLLER	1			3 5597
35	ECC012GN001	CABLE GLAND	1			4 6308
36	TAC000FC003	OIL COOLER	1			5 6469
37	HOC010AB041	LOW PRESSURE HOSE	1			6
38	FPC013AB001	BARREL	1			7
39	TAC000PA006	RETURN PIPE	1			8
40	EMC024BA011	LOW PRESSURE TRANSDUCER	1			9
41	VFC003WH016	RESTRICTOR	1			10
42	VFA006FH002	CHECK VALVE	1			11
43	SEC013RA001	O-RING - I.D. 9.25mm, C.S. 1.78mm, NITRILE 90	1			12
44	EMC024BA700	HIGH PRESSURE TRANSDUCER	1			13
45	HDTG1E	DIGITAL GAUGE WITH TRANSDUCER	1			14
46	BLC006JH030	M6 x 30 SOCKET BUTTON HEAD SCREW	4			15
47	NUC016LS001	M16 CABLE GLAND	1			16
*	BPC020SP002	FILLER PLUG	1			17
						18
						19
						20

NOTE:

- ALL PARTS AVAILABLE TO BE ORDERED AS SPARE PARTS (UNLESS MARKED WITH *).
- PARTS MARKED WITH ✓ ARE **ONLY** AVAILABLE IN SERVICE KIT **TPE-DTP2-K**.
- FOR SUB ASSEMBLIES (ITEM NO's **1** & **8**) PLEASE REFER TO THEIR INDIVIDUAL EVD's.

IMPORTANT

WHEN ORDERING SPARES YOU MUST STATE THE FULL PART NUMBER AND THE PRODUCT SERIAL NUMBER - FROM THE LABEL TO PROTECT YOUR WARRANTY ALWAYS USE GENUINE HI-FORCE PARTS.

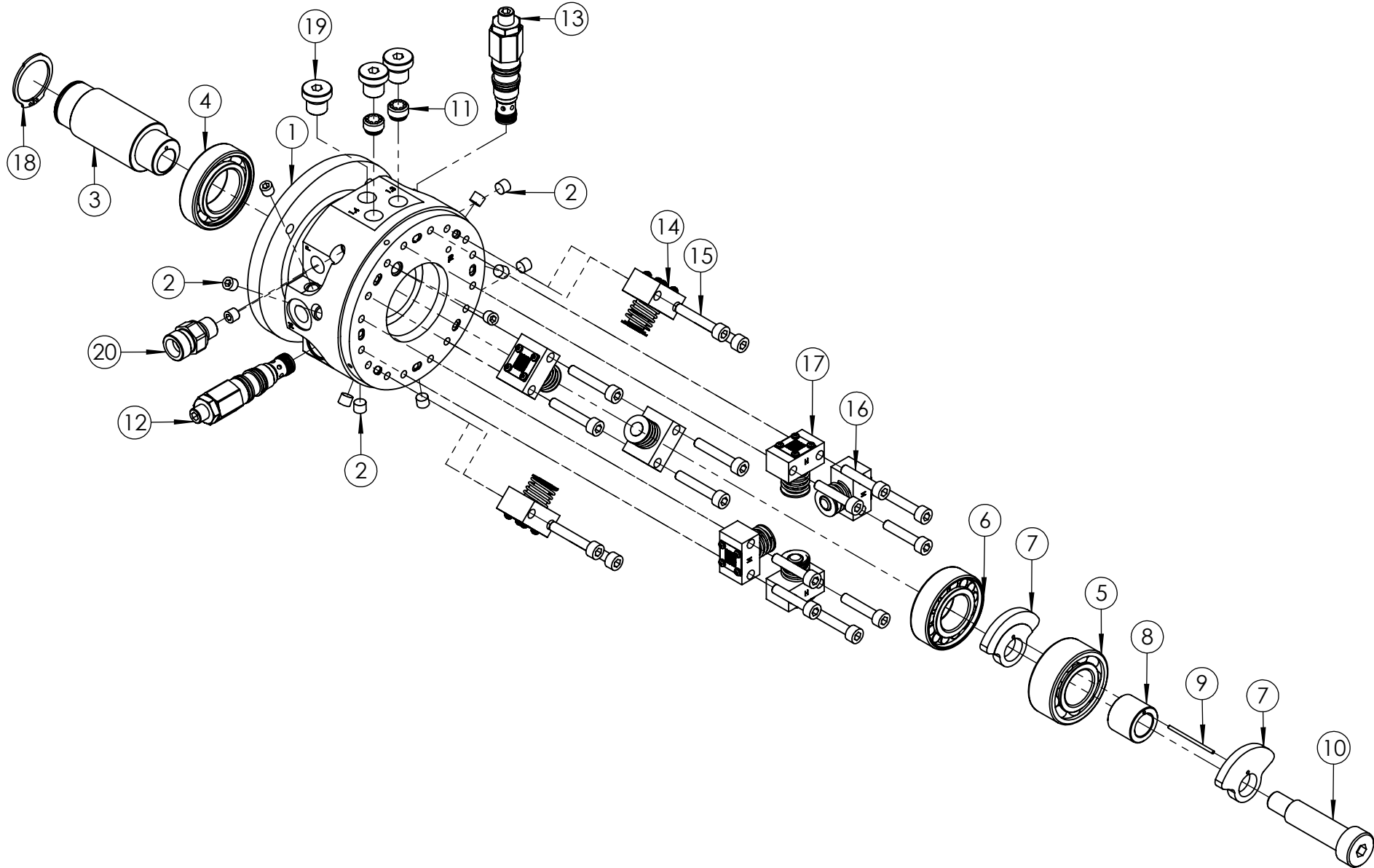

REVISION

1	4085
2	4283
3	4408
4	4440
5	5494
6	5789
7	6308
8	
9	
10	
11	
12	
13	
14	
15	
16	
17	
18	
19	
20	

IMPORTANT
WHEN ORDERING SPARES YOU MUST STATE THE FULL PART NUMBER AND THE
PRODUCT SERIAL NUMBER - FROM THE LABEL
TO PROTECT YOUR WARRANTY ALWAYS USE GENUINE HI-FORCE PARTS.

ITEM NO.	PART NUMBER	DESCRIPTION	QTY.	SPARE PARTS
1	PMC000KM002	PUMP BODY	1	X
2	FPC002PN001	1/16"NPTF x 7/8" TAPER PLUG	11	
3	PMC019SM001	DRIVE SHAFT	1	
4	BSC030MC001	DEEP GROOVE BALL BEARING	1	
5	BSC025ME001	DOUBLE ROW BEARING	1	
6	BSC025NC001	CYLINDRICAL ROLLER BEARING	1	
7	PMC019EM001	COUNTERWEIGHT	2	
8	PMC019RM001	BUSH	1	
9	PCC002FE001	LOCATING PIN	1	
10	BLC016NS050	SHOULDER SCREW	1	
11	VFA006FH001	CHECK VALVE	2	
12	VRC065UF001	UNLOADING VALVE 65 BAR	1	
13	VRC320UF001	UNLOADING VALVE 320 BAR	1	
14	PEA011AA001	LP PISTON BLOCK	4	
15	BLC006JD035	SOCKET CAP HD SCREW	8	
16	BLC006JD030	M6 x 30 mm HEX SOCKET CAP HEAD SCREW	8	
17	PEA006AA002	HP PISTON BLOCK	4	
18	STC030CA002	CIRCLIP	1	
19	FPC006PB002	BLANKING PLUG	3	
20	FPC006YW001	COUPLING BODY	1	

NOTE:

- ALL PARTS ARE AVAILABLE TO BE ORDERED AS INDIVIDUAL SPARE PARTS (UNLESS MARKED WITH **X**).

REVISION

1	4085
2	4283
3	4408
4	4440
5	5494
6	5789
7	6308
8	
9	
10	
11	
12	
13	
14	
15	
16	
17	
18	
19	
20	

IMPORTANT

WHEN ORDERING SPARES YOU MUST STATE THE FULL PART NUMBER AND THE PRODUCT SERIAL NUMBER - FROM THE LABEL TO PROTECT YOUR WARRANTY ALWAYS USE GENUINE HI-FORCE PARTS.

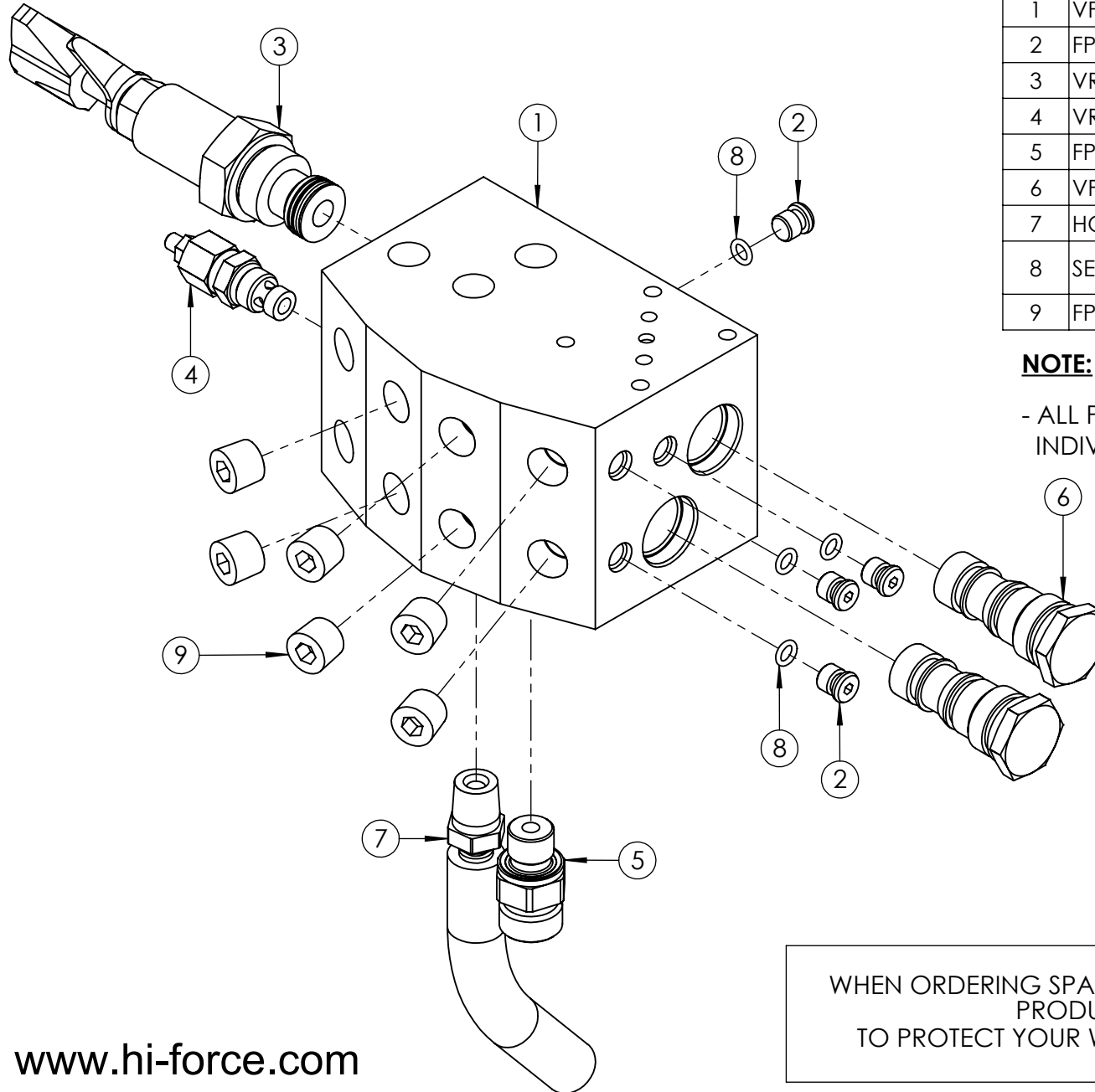

ITEM NO.	PART NUMBER	DESCRIPTION	QTY.	SPARE PARTS	REVISION
1	VFC006RN002	VALVE BLOCK	1	X	1 4376
2	FPC008PM003	PLUG	4		2 4496
3	VRC700ZE002	ADJUSTABLE RELIEF VALVE	1		3 4518
4	VRC080ZF001	LOW PRESSURE RELIEF VALVE	1		4 5552
5	FPC006YW001	COUPLING BODY	1		5 5623
6	VFA000LH001	PILOT OPERATED VALVE	2		6 6308
7	HOC006AB005	RETURN HOSE	1		7
8	SEC008RA002	O-RING - I.D. 5.0 mm C.S. 1.5 mm, NITRILE 70	4		8
9	FPC006PN002	1/4 NPT x 7/8 TAPER PLUG	6		9
					10
					11
					12
					13
					14
					15
					16
					17
					18
					19
					20

NOTE:

- ALL PARTS ARE AVAILABLE TO BE ORDERED AS INDIVIDUAL SPARE PARTS (UNLESS MARKED WITH X).

IMPORTANT

WHEN ORDERING SPARES YOU MUST STATE THE FULL PART NUMBER AND THE PRODUCT SERIAL NUMBER - FROM THE LABEL TO PROTECT YOUR WARRANTY ALWAYS USE GENUINE HI-FORCE PARTS.

ITEM NO.	PART NUMBER	DESCRIPTION	QTY.	REVISION
1	WAC007HD000	1/4" BSP SELF CENTERING BONDED WASHER	1	1 6469
2	WAC012HD001	DOWTY WASHER	2	2
3	SEC119RF001	O-RING I.D. 75.57MM, CS 5.33MM 70 SHORE (BS157)	1	3
4	SEC001KT005	VALVE GASKET	1	4
5	SEC001KT008	TANK GASKET	1	5
6	SEC002KT017	PUMP GASKET	1	6
				7
				8
				9
				10
				11
				12
				13
				14
				15
				16
				17
				18
				19
				20

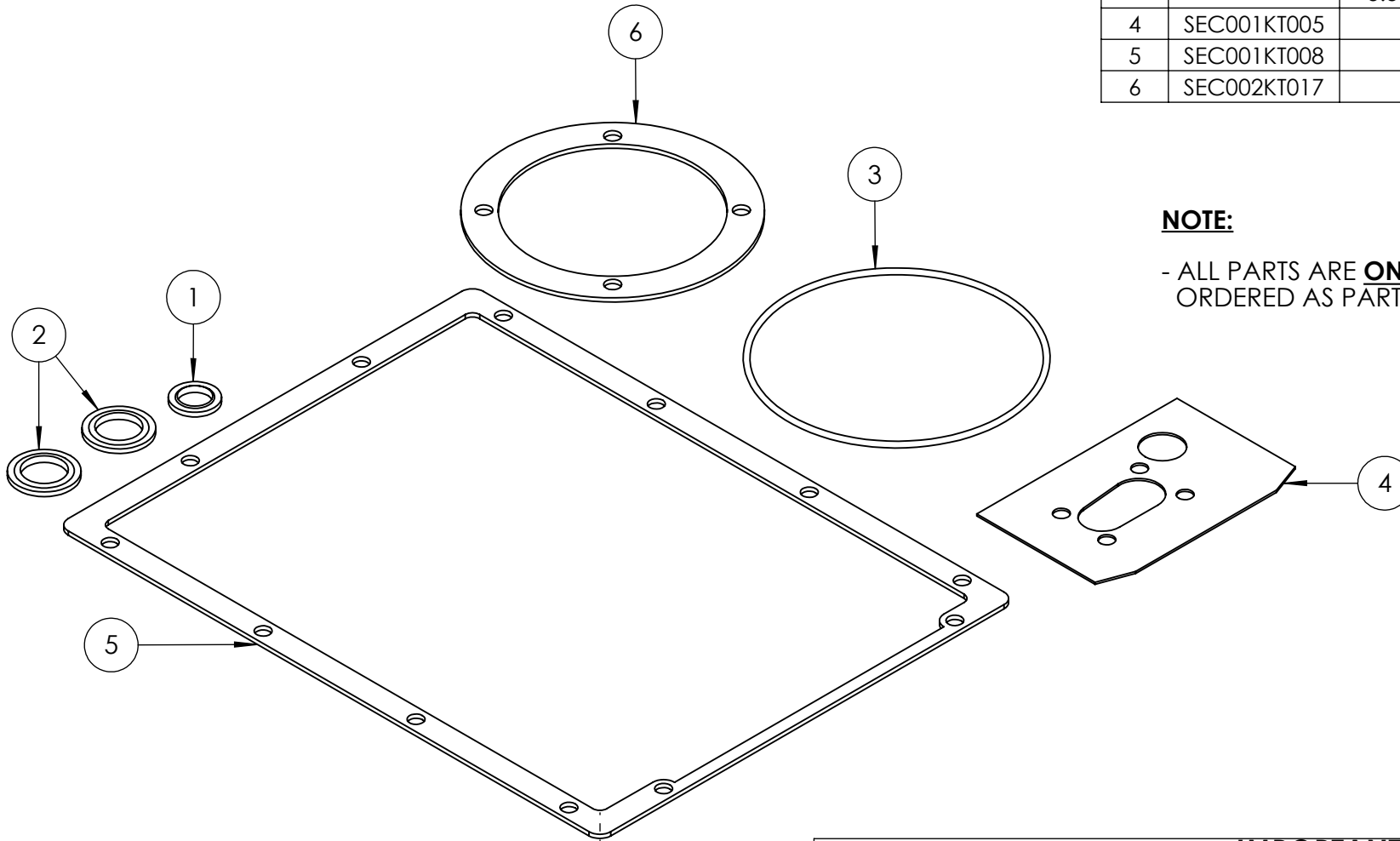

NOTE:

- ALL PARTS ARE **ONLY** AVAILABLE TO BE ORDERED AS PART OF SEAL KIT.

IMPORTANT

WHEN ORDERING SPARES YOU MUST STATE THE FULL PART NUMBER AND THE PRODUCT SERIAL NUMBER - FROM THE LABEL TO PROTECT YOUR WARRANTY ALWAYS USE GENUINE HI-FORCE PARTS.